

單級雙吸離心泵

SINGLE-STAGE DOUBLE SUCTION CENTRIFUGAL PUMP



联系我们

WWW.U-FLO.CN

营销中心 Marketing Center

ADD: 南京市中山东路288号新世纪广场A幢1006室 (210002)
Room 1006, Block A, New Century Plaza, 288# Zhongshan East Road, Nanjing
TEL: (86) 25-52231105 / 52230907 / 52230921 / 84846376 FAX: (86) 25-52230912

生产中心 Production Center

ADD: 南京市溧水经济开发区南区罗马工业园18号 (210012)
18# Rome Industry Park, Southern District, Lishui Economic Development, Nanjing
TEL: (86) 25-56610801 / 56610802 / 56610803 / 56610805 / 56610815 FAX: (86) 25-56610806

销售服务热线: 400-100-8486 售后服务热线: 800-828-9695

南京方卓品牌设计 | www.njzad.com

FS SERIES
DOUBLE SUCTION
CENTRIFUGAL
PUMP



Contents 目录

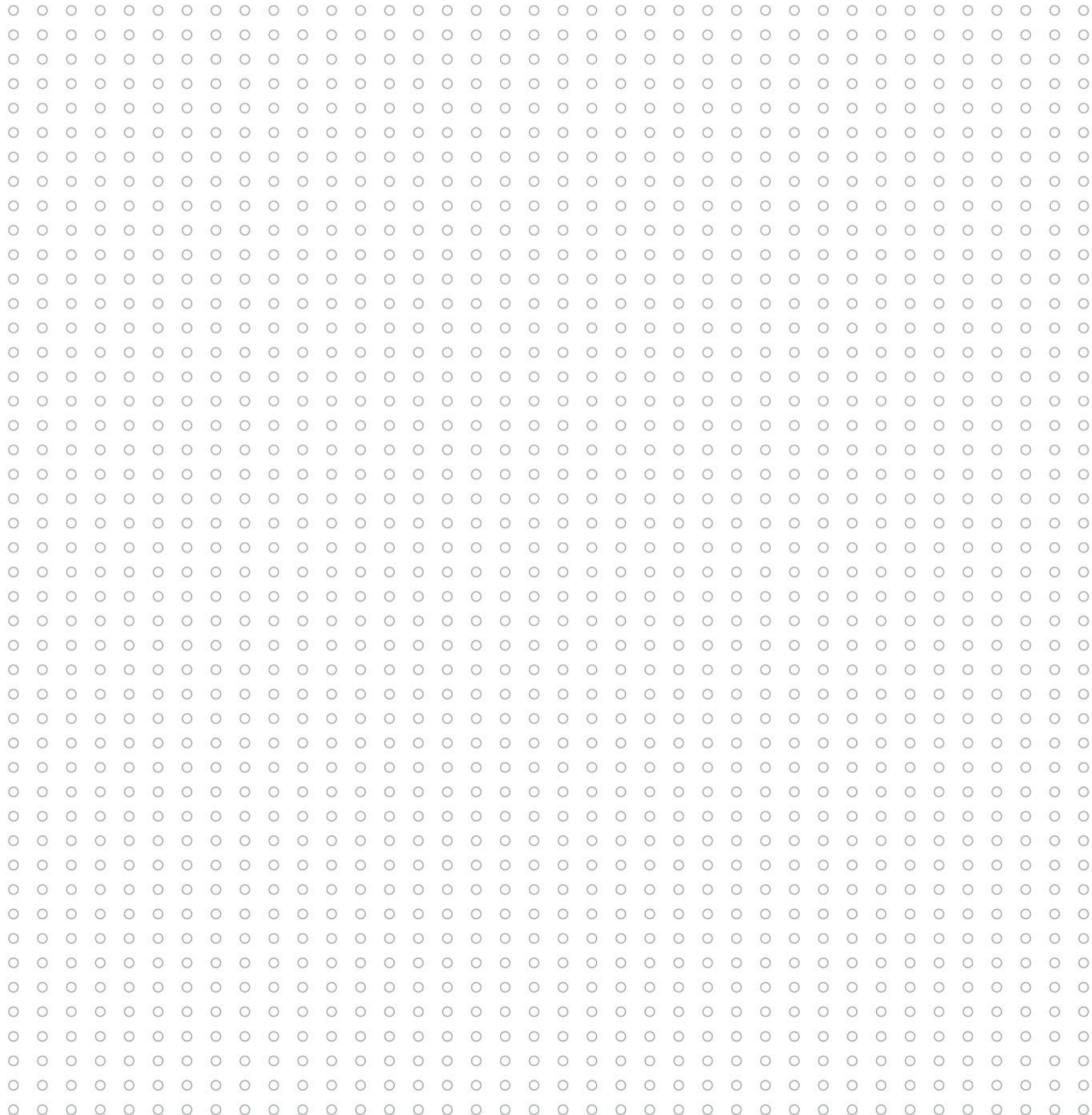

03/04 COMPANY PROFILE 公司介绍

U.S. U-flo

美国尤孚

U-flo in China

尤孚中国

05/66 PRODUCTS 产品介绍

FS SERIES

单级双吸离心泵

PERFORMANCE CURVES

单级双吸泵型谱

PERFORMANCE CURVE CHART

性能曲线图

PERFORMANCE DATA

性能参数

PERFORMANCE DATA

法兰尺寸图

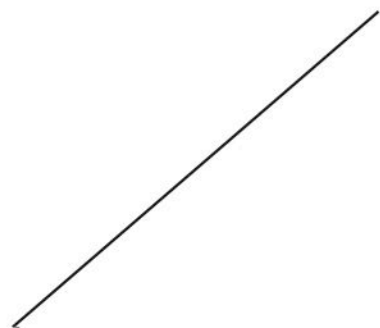



U-flo Pumps International LLC is a global water pump manufacturing and marketing company registered in Washington, USA. Our cooperated facilities are located in Italy, Japan, Taiwan and China. Our primary products include Deep-well Pumps, Above-ground Pumps, Sewage Pumps, Pumping Systems. They are widely used in power plants, paper mills, steel plants, agriculture irrigations, construction trades, industrial applications, mining operations, municipal utilities as well as oil/gas fields.

Integrity, Innovation, International

Since the first U-FLO water pump was manufactured, our people have been making unremitting endeavor to improve designs of the U-FLO water pump products. We apply the best industry practices and the best suitable materials for key components to the design and manufacturing of our pumps.

In addition to our state of art manufacturing facilities, we put a big effort on pump testing. Every product undergoes a rigorous testing and inspection process before being shipped to our customers. Our test facility incorporates a 12000 cubic meter (52,834 gallon) closed loop system with testing capacity of up to 600m³/h (2640GPM) with the maximum head of 200m (656ft), and 250 horsepower (dual voltages of 50Hz and 60Hz). Following a strict quality management system, all of our facilities are ISO 9001 and ISO 4001 certified.

Water is a vital part of our natural resources. While we always pursue the excellence of our products and services, we also take every step to promote environment-friendly and energy-saving solutions.

As a global pump manufacturer and supplier, U-FLO is committed to producing the finest water pumps in the world and continues to lead the way forward in the pumping industry.

U-FLOPUMPS INTERNATIONAL LLC 是一家总部注册在美国华盛顿州的全球化水泵制造与销售公司。我们在意大利, 日本, 台湾和中國大陸地区均设有合作工厂。我们主要产品包括深井泵、地面泵、污水泵和供水设备。产品广泛应用于电厂、造纸厂、钢厂、农业灌溉、建筑、工业应用、矿山、市政以及油田领域。

诚信、创新、国际化

自第一台 U-flo 水泵出厂以来, 我们一直不懈努力, 致力于改进 U-flo 水泵的设计。我们以最高的行业要求和最佳材料设计和制造水泵。

在严抓工艺水平的同时, 我们还致力于水泵的测试。每一台水泵在出厂前均需要经过严格的测试和检验。我们的测试台含 12000 立方米 (52,834 加仑) 闭式循环系统, 最大测试流量达 600m³/h(2640GPM), 最高扬程为 200m(656ft), 250 马力 (双电压 50Hz、60Hz)。按照严格的质量管理体系, 我们所有的工厂均通过 ISO9001 和 ISO14001 认证。

水是自然资源的重要组成部分, 我们在追求卓越的产品和服务的同时, 亦在努力推广环保和节能解决方案。

作为全球水泵制造商和供应商, U-flo 致力于生产全球最好的水泵, 成为水泵行业的领跑者。



Quality witness responsibility Technology create reliability

品质见证责任 专业成就信赖!



Design & production 设计和制造

Design and production are all made internally at U-flo's facilities, with a quality and process systems in accordance to the ISO9001 standards; as a further results of its environmental orientation, U-flo, in the 2005, got the ambitious ISO14001 Certificate proving that its production processes comply with the very strict rules imposed by the IO14001 Certificate.

U-flo自主设计和制造，质量及生产系统符合ISO9001标准。更因为U-flo准确的环境定位，2011年获得ISO14001认证，充分证明生产过程符合ISO14001标准。

Product application scope 产品应用范围

Wide application field: it can be widely used in high-rise water supply, building fire protection, central air conditioning cycle, circulating water supply of engineering system, cooling water circulation, boiler water supply, industrial water supply and draining, irrigation, especially apply to water plants, power plants, paper plants, steel plants and chemical plants.

应用领域广：可广泛应用于高楼供水，建筑消防，中央空调水循环。工程系统中循环供水、冷却水循环、锅炉供水、工业给水排水、水利灌溉、特别适用于水厂、电厂、纸厂、钢厂，化工厂。

U-FLO reserves the right to make modifications without notice.

U-FLO 有权对产品进行修改，恕不另行通知。



DOUBLE SUCTION CENTRIFUGAL PUMP

DOUBLE SUCTION CENTRIFUGAL PUMP

FS SERIES / 单级双吸离心泵
FS系列

I、Features

1. Excellent hydraulic model: high efficiency up to 97%.
2. Different shaft seals are available, such as packing seal, injected soft packing seal and mechanical seal.
3. Independent shaft seal box: packing seal, injected soft packing seal and mechanical seal can be exchanged by changing shaft seal parts without moving other parts.
4. Double shaft extension: pump can be driven by both ends as customer required without any position limitation.
5. Reliable bearing and seal: adopt imported SKF or NSK bearing and oil seal. Bearing is lubricated by grease or oil with multi protection.
6. Wear-resistant & corrosive-resistant shaft sleeve design: main shaft is protected by shaft sleeve. The pumped medium will not contact with main shaft directly in actual operation, thus cause no wear to the main shaft.
7. Reliable bearing base location: adopt locating pin or fluting location. Semi structure bearing is easy to install and maintain.
8. The main shaft standard material is 2CR13, 304SS, 316SS or 904L is available. Bolts and other connecting parts can adopt all stainless steel material.

- 1.最佳的水力模型——效率高，最高效率可达97%。
- 2.轴封有填料密封，注入式软填料密封，机械密封等多种形式可选择。
- 3.独立的轴密封盒——其余零件不动，只要更换轴封部件，可以实现填料，注入式的软填料，单端面，双端面，机械密封等密封形式的互换。
- 4.泵轴采用双轴伸式结构——可以分别由泵的两端驱动，不受场地限制，在泵的哪一端可由用户随意确定。
- 5.可靠的轴承及密封：采用进口SKF或NSK深沟球轴承和油封，轴承采用脂或油润滑，并对轴承采用多层保护措施。
- 6.耐磨、耐蚀轴保护套的设计：主轴被轴套保护，实际运行中主轴无摩擦，同时不与所抽送介质直接接触。
- 7.轴承座定位可靠：其定位分别采用定位销或止口形式定位，定位可靠。FS泵轴承座采用分半式结构，易安装维护。
- 8.主轴的正常最低配置为2CR13，可选配304，316，904L等材质。螺栓等联接件可以全部选用不锈钢材质。

II、STRUCTURE DIAGRAM 结构示意图

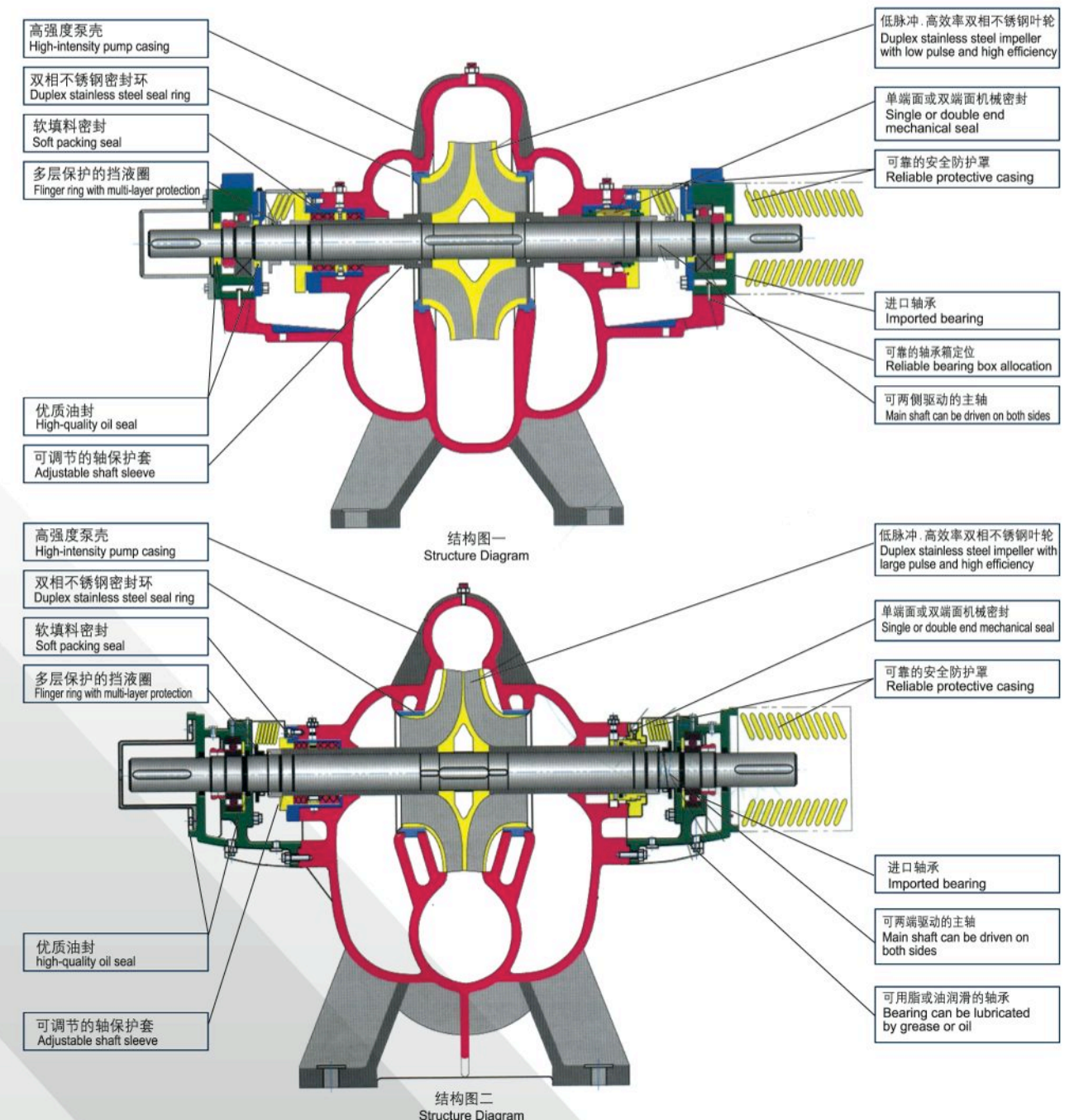

DOUBLE SUCTION CENTRIFUGAL PUMP

FS SERIES / 单级双吸离心泵 FS系列

III、FEATURES 特点

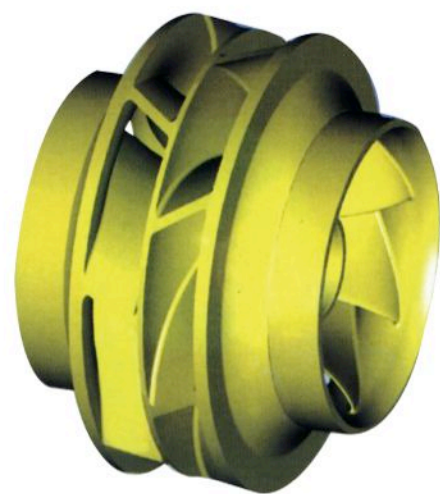

OPTIMIZED HYDRAULIC MODEL 最佳水力模型

Hydraulic model was designed by advanced computing method of fluid mechanics and computer-aided method.
用先进的流体力学计算方法及计算机辅助方法设计的水力模型

DUAL-PHASE FLOW IMPELLER, SYMMETRICAL IMPELLER 双相流叶轮、对称式叶轮

Low energy loss Optimized flow performance High efficiency
低耗冲 优化的流动性能 高效率

DIAPHRAGM COUPLING 膜片式联轴器

Excellent automatically compensated centration ability
自动补偿对中能力强

High transmission efficiency, obvious damping action
传动效率高，有明显的减震作用

DOUBLE SHAFT EXTENSION 泵轴双轴伸向

Can be driven on both ends
可以分别由泵的两端驱动

INDEPENDENT SHAFT SEAL CHAMBER 独立的轴密封腔体

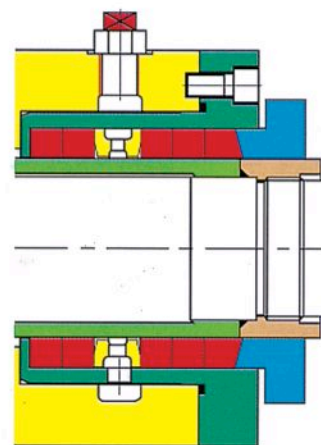

Packing seal 填料密封

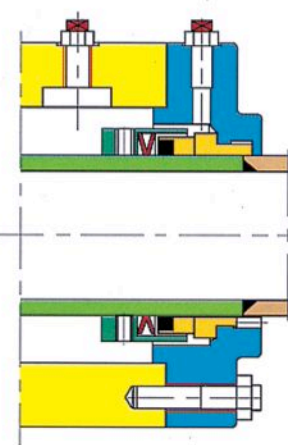

Single end mechanical seal 单端面机械密封

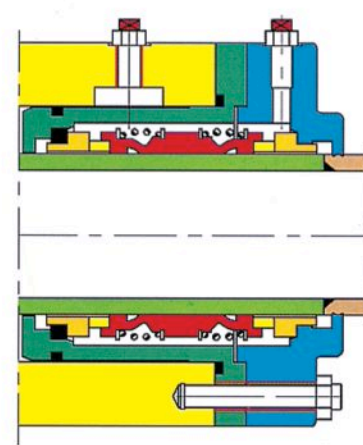

Double-end mechanical seal 双端面机械密封

DOUBLE SUCTION CENTRIFUGAL PUMP

FS SERIES / 单级双吸离心泵 FS系列

IV、PUMP STRUCTURE 泵的结构

STRUCTURE DIAGRAM 结构示意图

1	Pump cover	泵盖
2	Pump body	泵体
3	Impeller	叶轮
4	Double suction seal ring	双吸密封环
5	Shaft sleeve	轴套
6	Shaft seal parts	轴封部件
7	Shaft seal casing	轴封护罩
8	Bearing gland	轴承体压盖
9	Bearing body	轴承体
10	Coupling sleeve	联轴器护罩
11	Bearing	轴承
12	Shaft	轴
13	Shaft sleeve	轴防护罩
14	Bearing cover	轴承盖

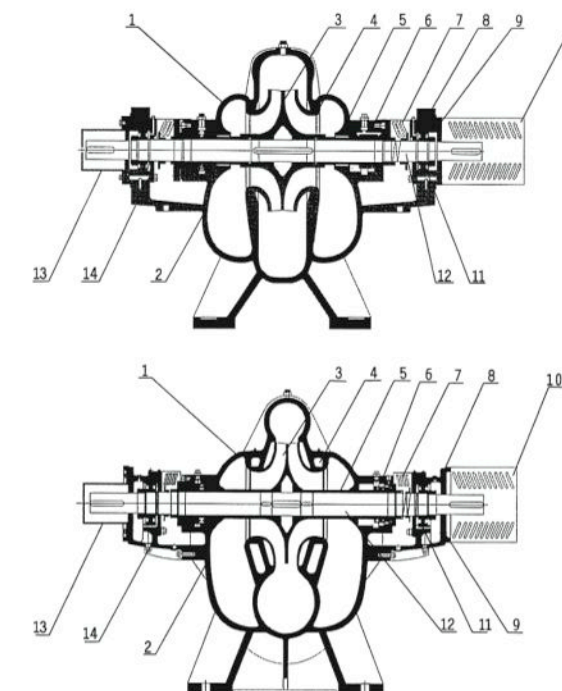

V、HIGH-QUALITY MATERIAL 优质材料

Part name 零件名称	Main material 主要材料			Part name 零件名称	Main material 主要材料		
	Ordinary IM(CC) 普通型IM(CC)	Standard IS(CD) 标准型IS(CD)	Enhanced WI(DD) 增强型WI(DD)		Ordinary IM(CC) 普通型IM(CC)	Standard IS(CD) 标准型IS(CD)	Enhanced WI(DD) 增强型WI(DD)
Pump body, pump cover 泵体、泵盖	HT250	HT250	1.4660 (铸)	Pump body, pump cover 密封函体	HT250	CF-8M	CF-8M
Impeller 叶轮	HT250	1.4660 (铸)	1.4660 (铸)	Impeller 密封压盖	HT250	CF-8M	CF-8M
Pump shaft 泵轴	40Cr	2Cr13	1.4662	Pump shaft 填料环	HT250	CF-8M	CF-8M
Shaft sleeve 轴套	ZG20Cr13	1.4660 (铸)	1.4660 (铸)	Shaft sleeve 挡液圈	ZG20Cr13	ZG20Cr13	ZG20Cr13
Double suction seal sleeve 双吸密封套	HT250	1.4660 (铸)	1.4660 (铸)	Double suction seal sleeve 轴承体、轴承盖	HT250	HT250	HT250
Sleeve nut 轴套螺母	45	2Cr13	2Cr13	Sleeve nut 螺栓等联接件	Q235A	OCr18Ni9	OCr18Ni9

DOUBLE SUCTION CENTRIFUGAL PUMP

FS SERIES / 单级双吸离心泵 FS系列

VI、PERFORMANCE CURVES FS单级双吸泵型谱

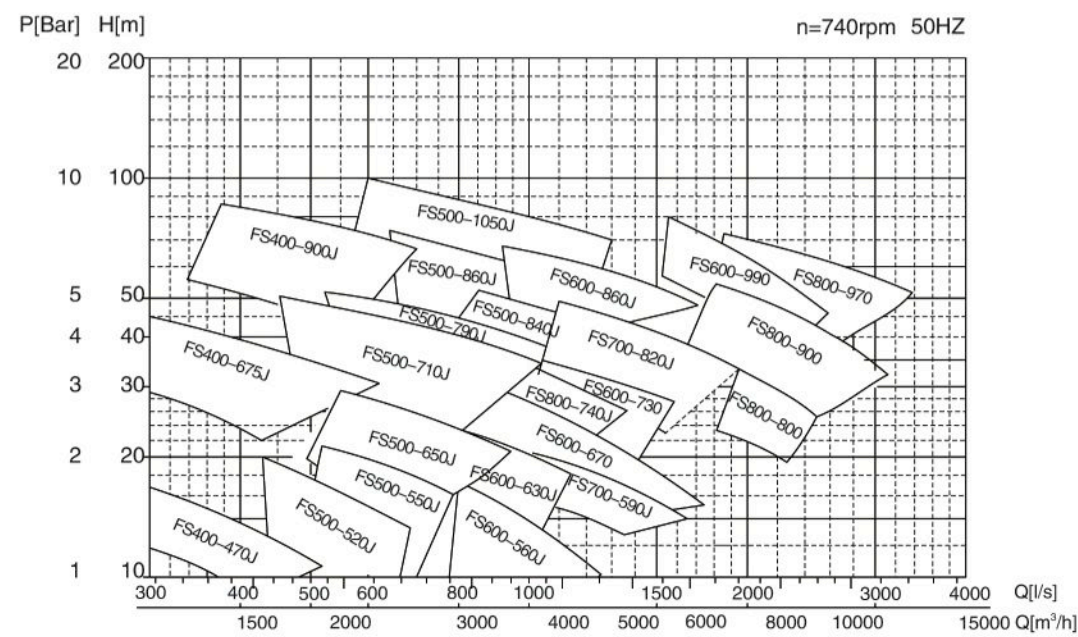
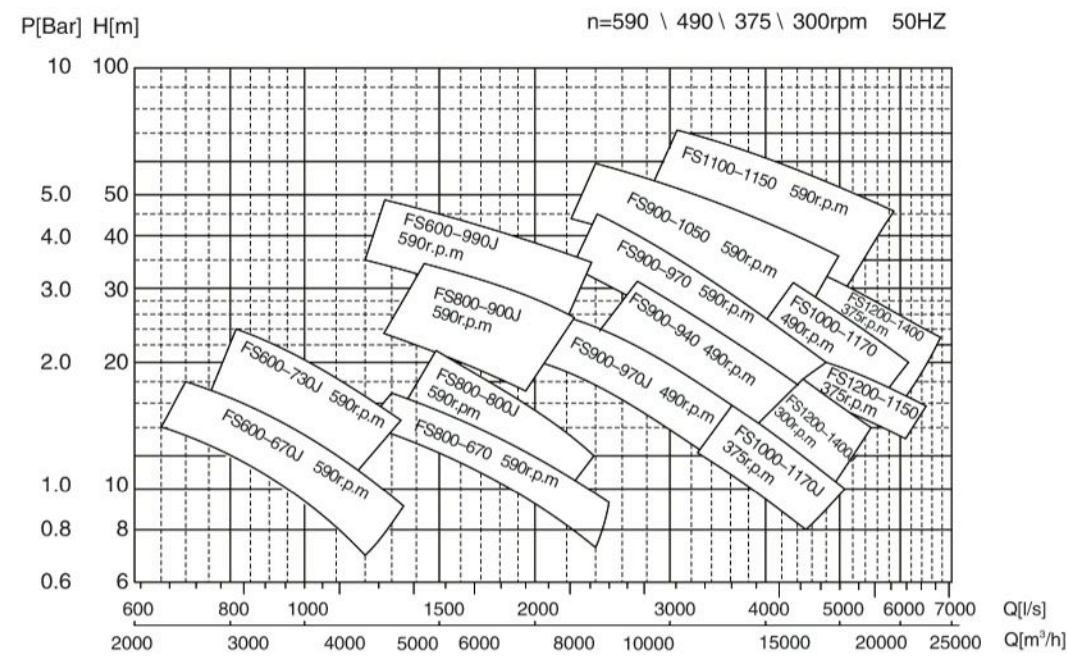

DOUBLE SUCTION CENTRIFUGAL PUMP

FS SERIES / 单级双吸离心泵 FS系列

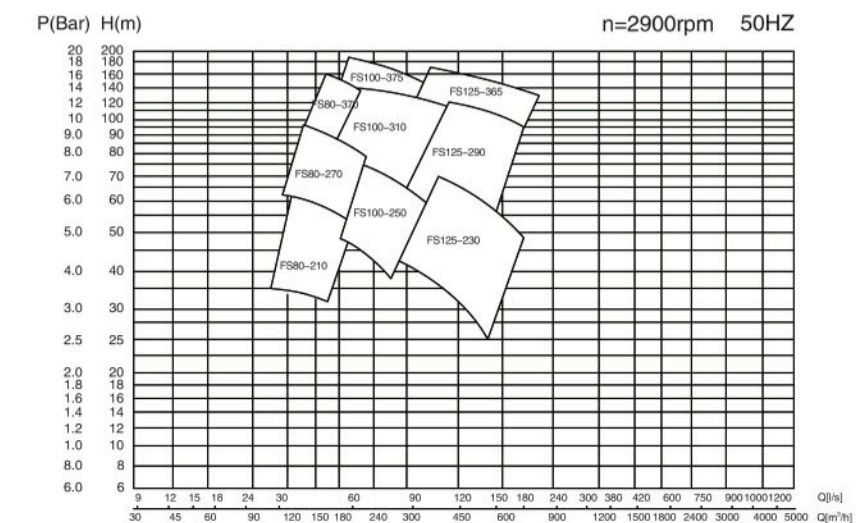
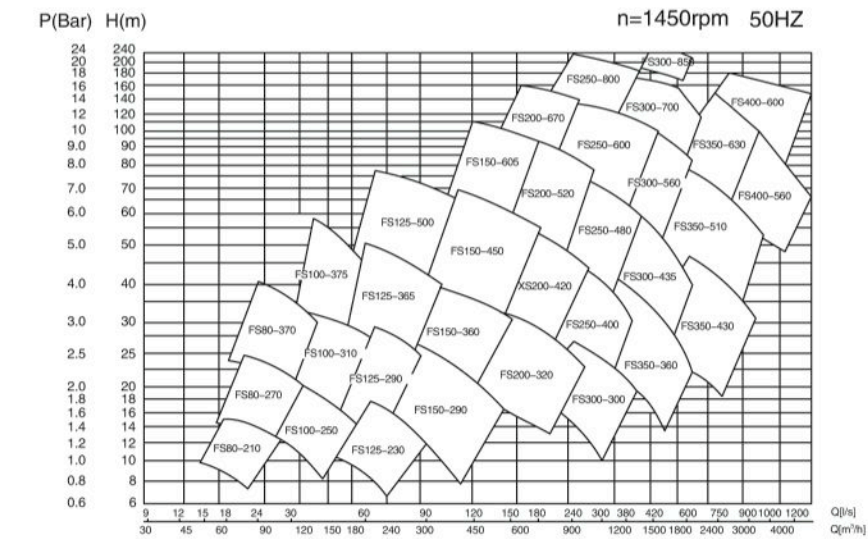
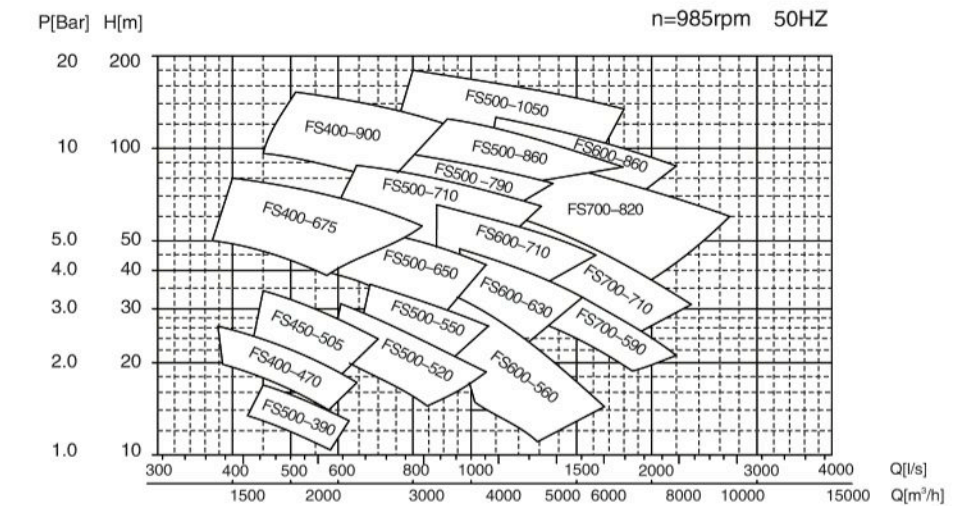

DOUBLE SUCTION CENTRIFUGAL PUMP

FS SERIES / 单级双吸离心泵
FS系列

VII、PERFORMANCE CURVE CHART 性能曲线图

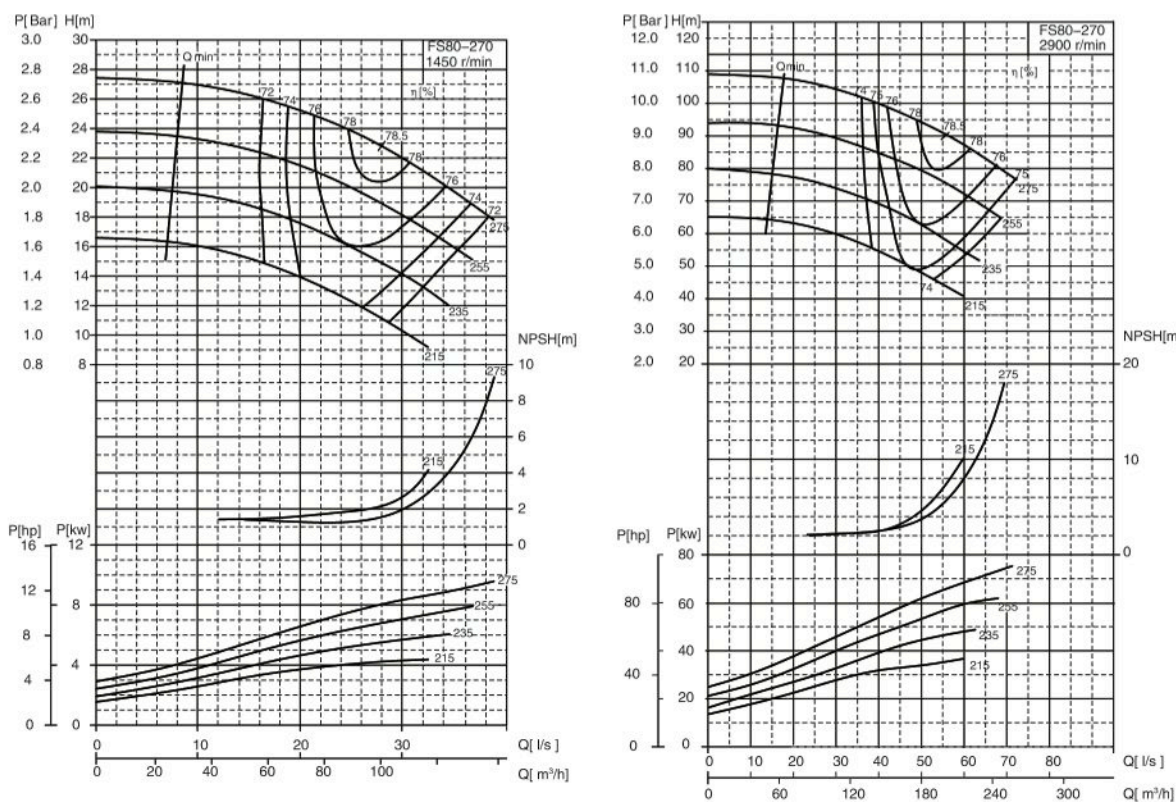
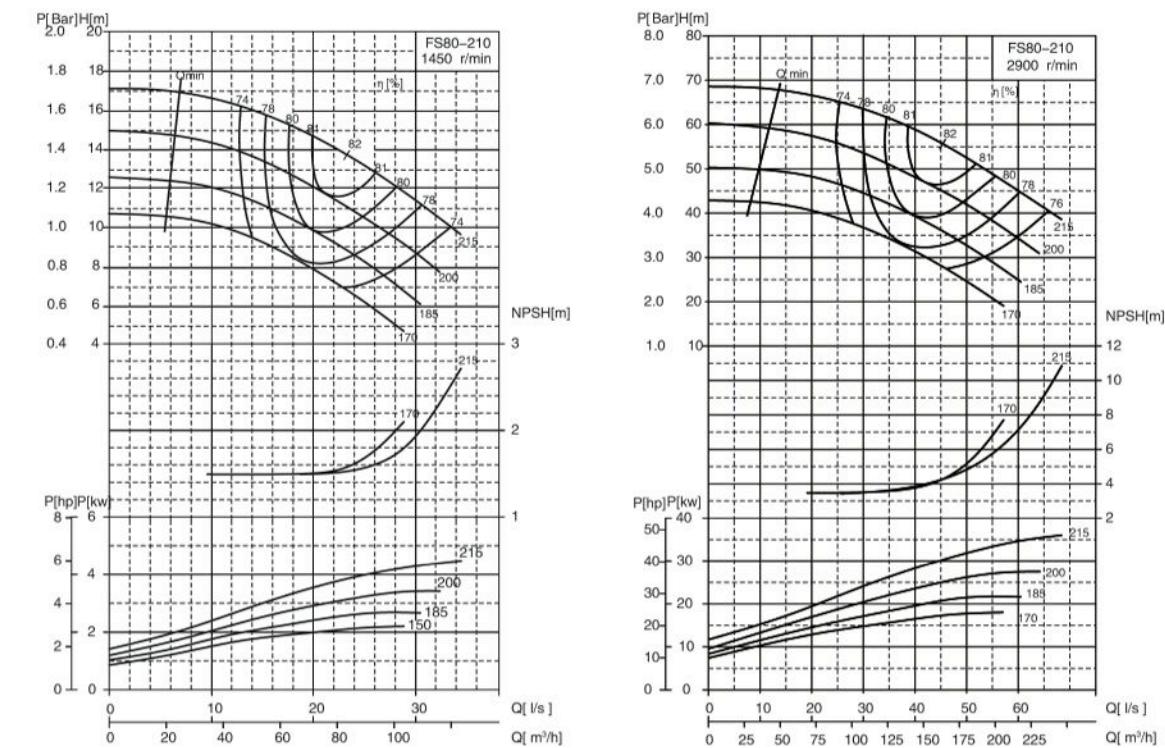

DOUBLE SUCTION CENTRIFUGAL PUMP

FS SERIES / 单级双吸离心泵
FS系列

VII、PERFORMANCE CURVE CHART 性能曲线图

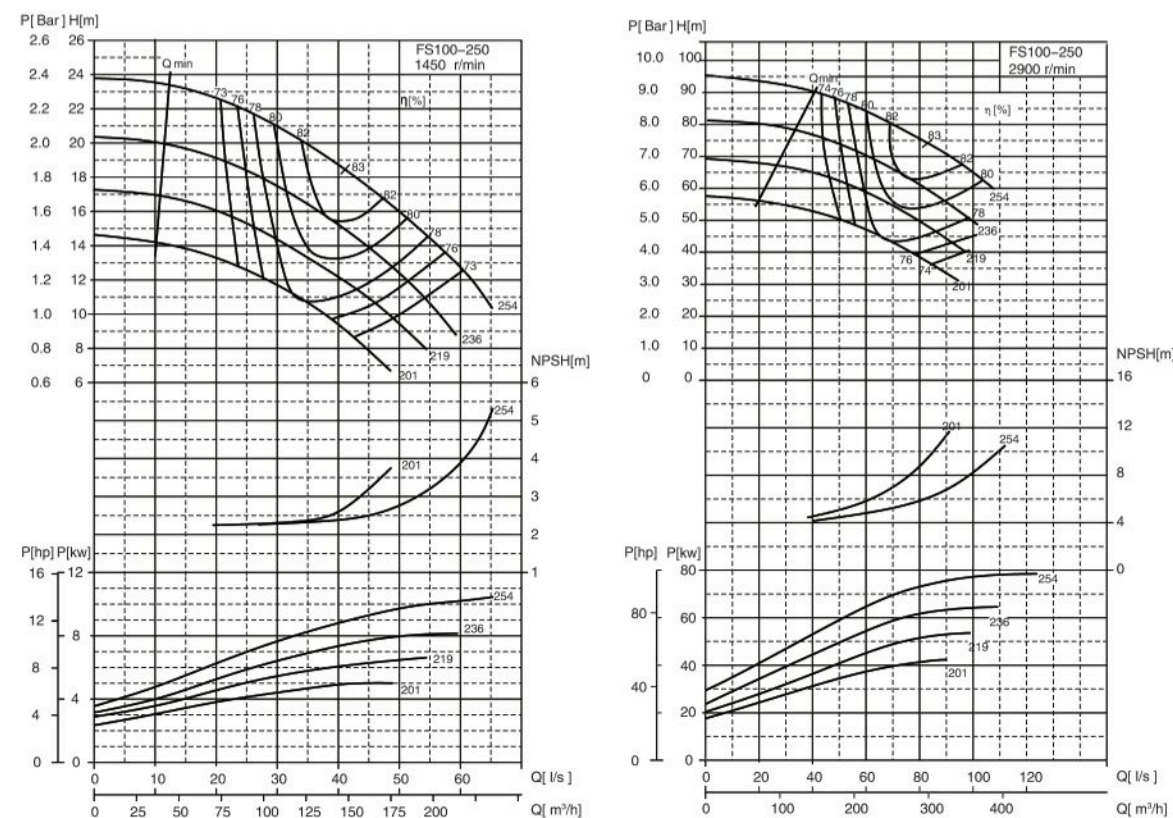
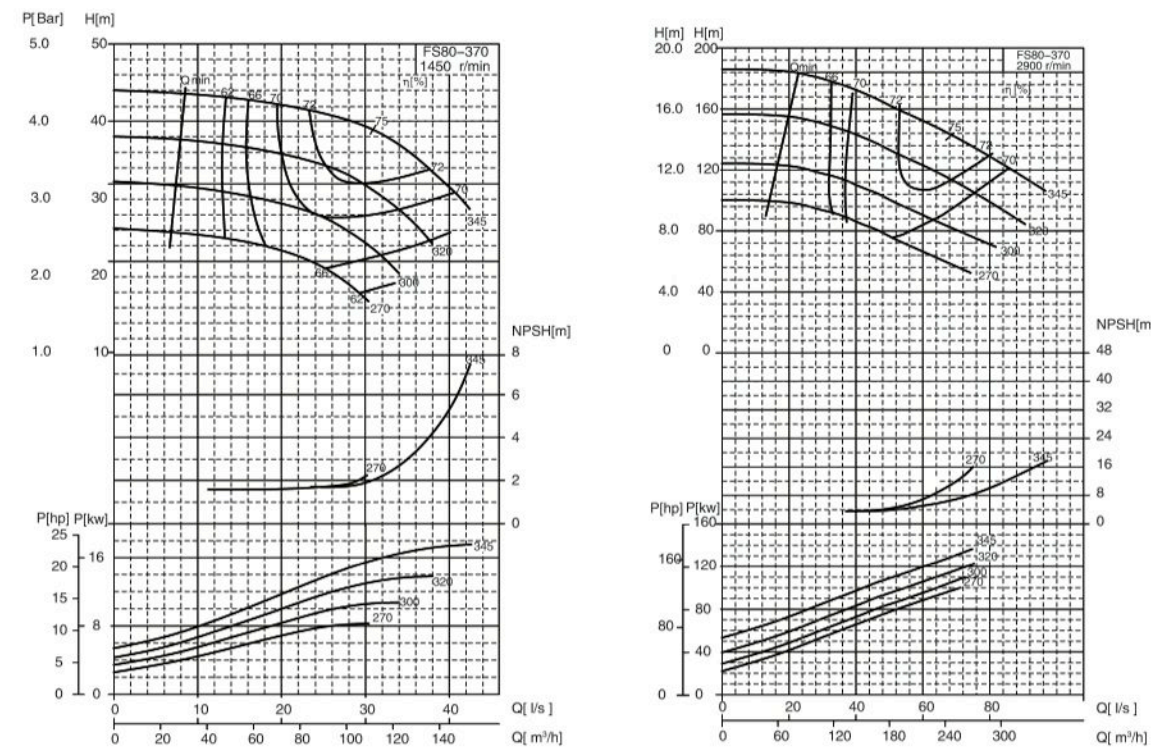

FS

FS80

FS100

FS125

FS150

FS200

FS250

FS300

FS350

FS400

FS450

FS500

FS600

FS700

FS800

FS900

FS1000

FS1100

FS1200

DOUBLE SUCTION CENTRIFUGAL PUMP

FS SERIES / 单级双吸离心泵
FS系列

VII、PERFORMANCE CURVE CHART 性能曲线图

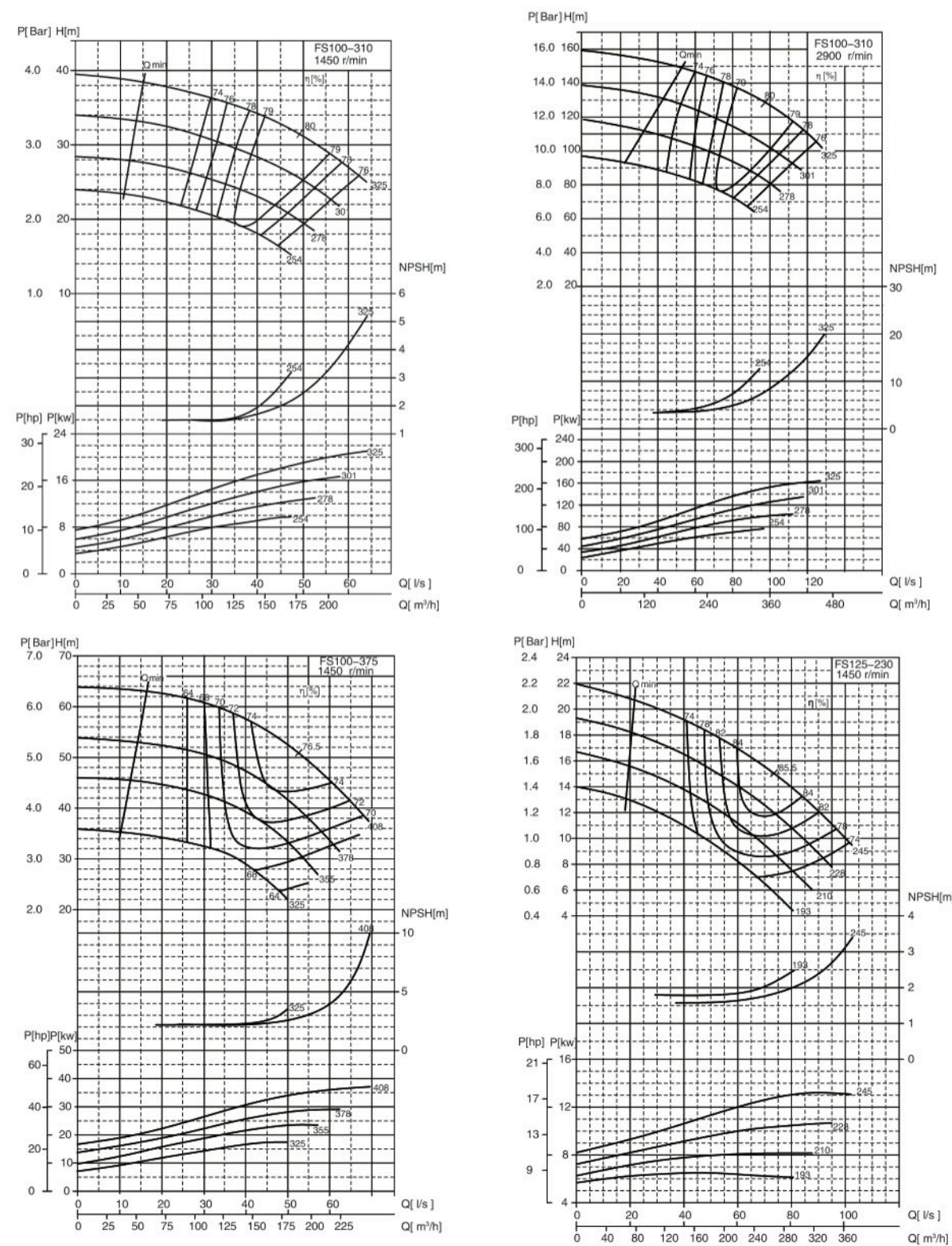

DOUBLE SUCTION CENTRIFUGAL PUMP

FS SERIES / 单级双吸离心泵
FS系列

VII、PERFORMANCE CURVE CHART 性能曲线图

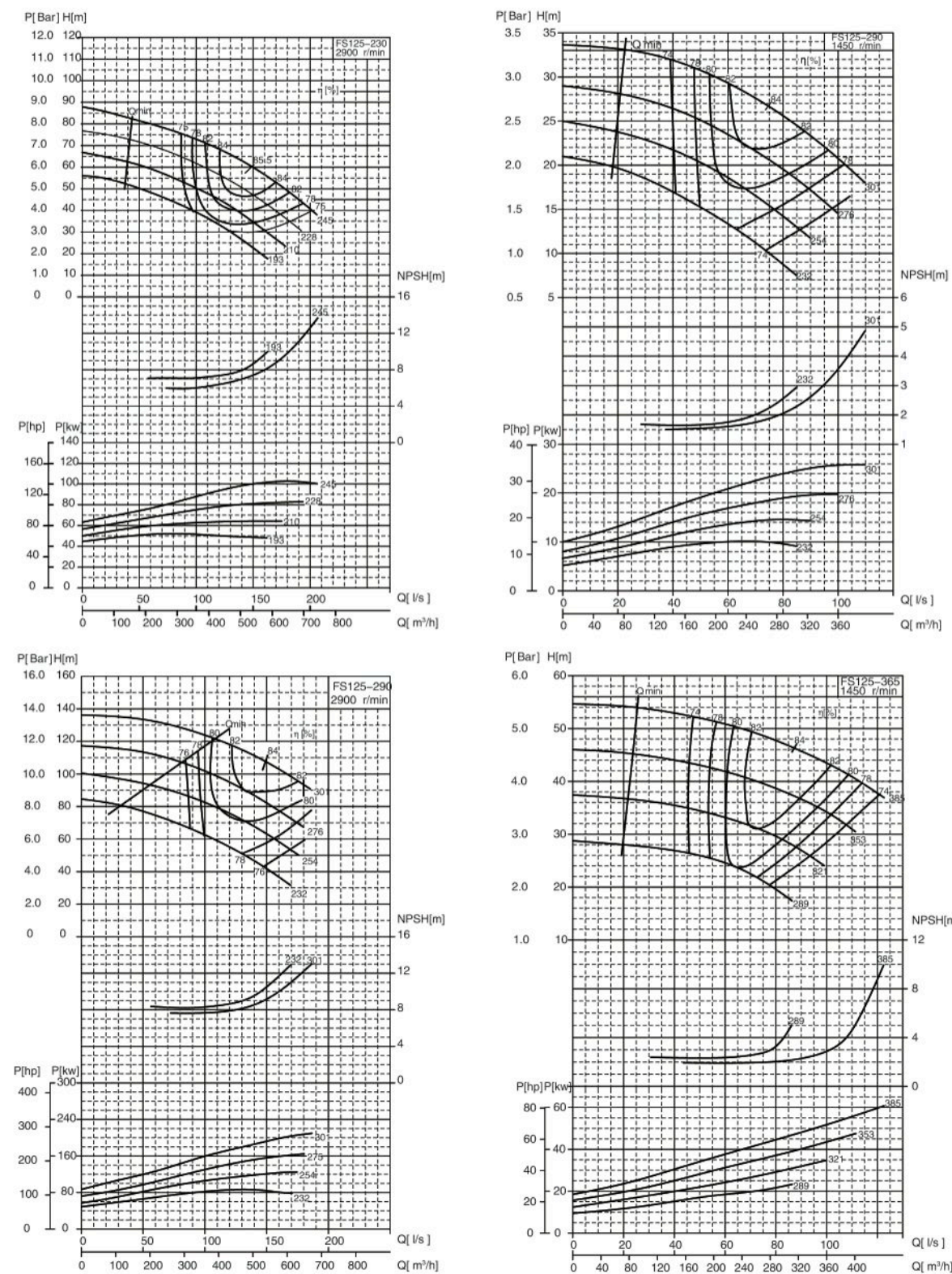

- FS
- FS80
- FS100
- FS125
- FS150
- FS200
- FS250
- FS300
- FS350
- FS400
- FS450
- FS500
- FS600
- FS700
- FS800
- FS900
- FS1000
- FS1100
- FS1200

DOUBLE SUCTION CENTRIFUGAL PUMP

FS SERIES / 单级双吸离心泵 FS系列

VII、PERFORMANCE CURVE CHART 性能曲线图

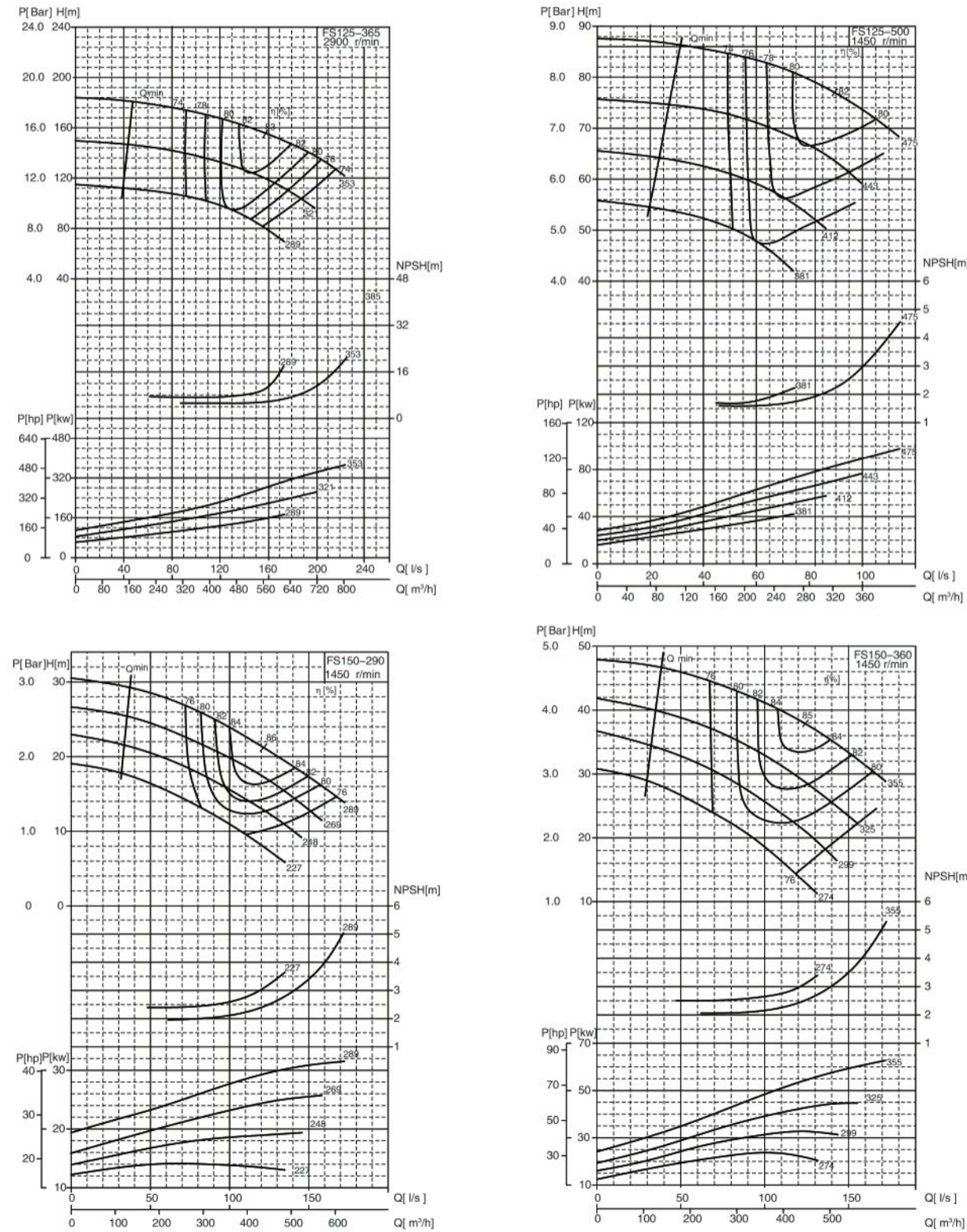

DOUBLE SUCTION CENTRIFUGAL PUMP

FS SERIES / 单级双吸离心泵 FS系列

VII、PERFORMANCE CURVE CHART 性能曲线图

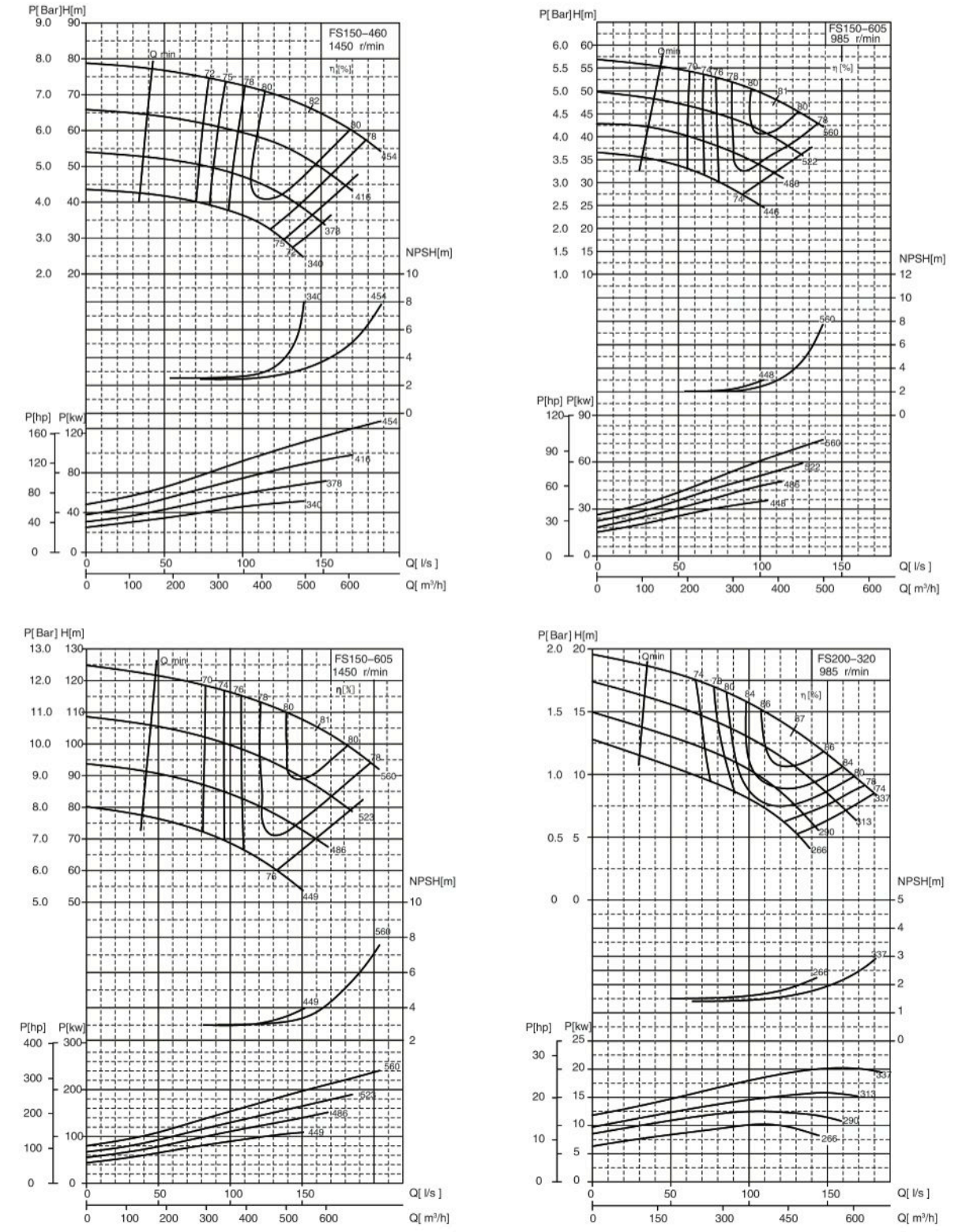

- FS
- FS80
- FS100
- FS125
- FS150
- FS200
- FS250
- FS300
- FS350
- FS400
- FS450
- FS500
- FS600
- FS700
- FS800
- FS900
- FS1000
- FS1100
- FS1200

DOUBLE SUCTION CENTRIFUGAL PUMP

FS SERIES / 单级双吸离心泵
FS系列

VII、PERFORMANCE CURVE CHART 性能曲线图

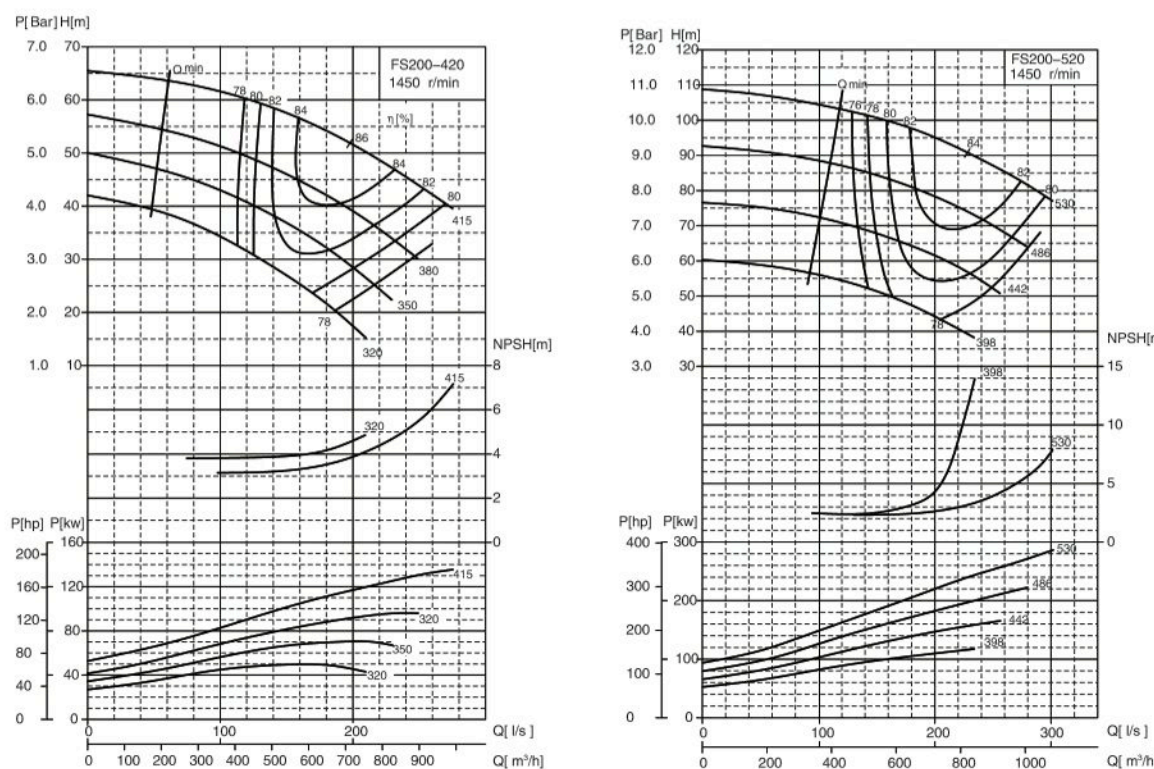
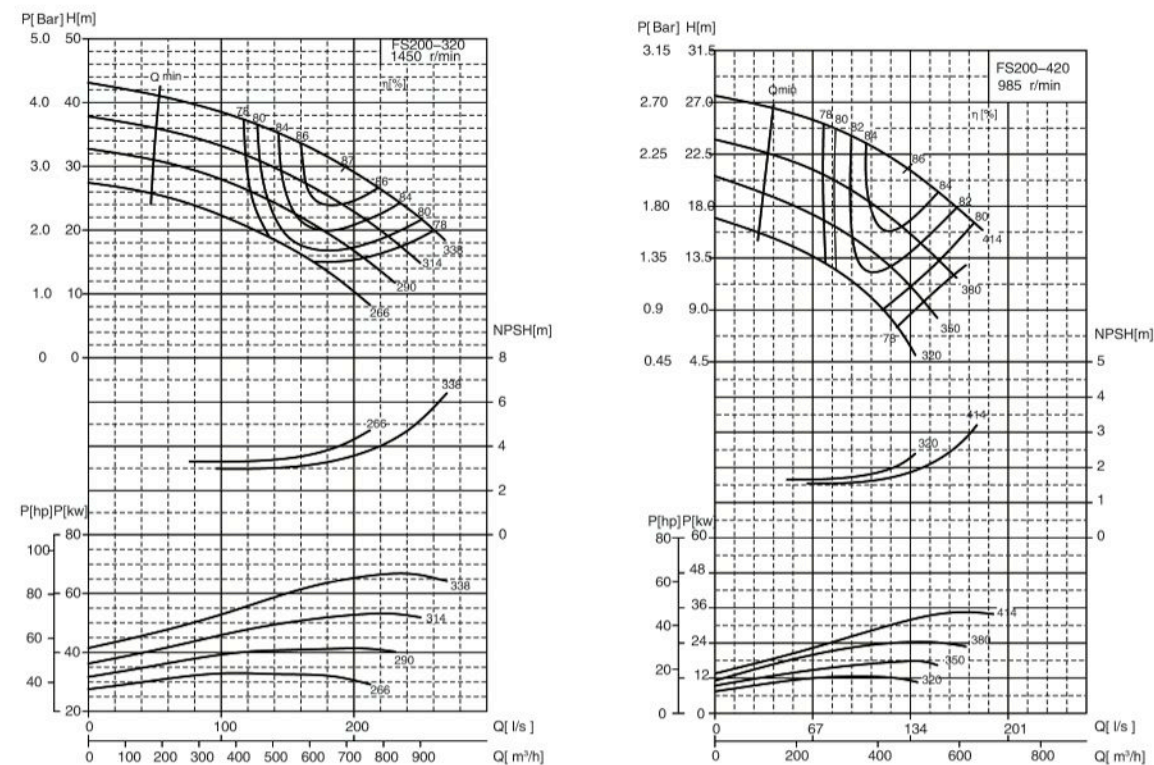

DOUBLE SUCTION CENTRIFUGAL PUMP

FS SERIES / 单级双吸离心泵
FS系列

VII、PERFORMANCE CURVE CHART 性能曲线图

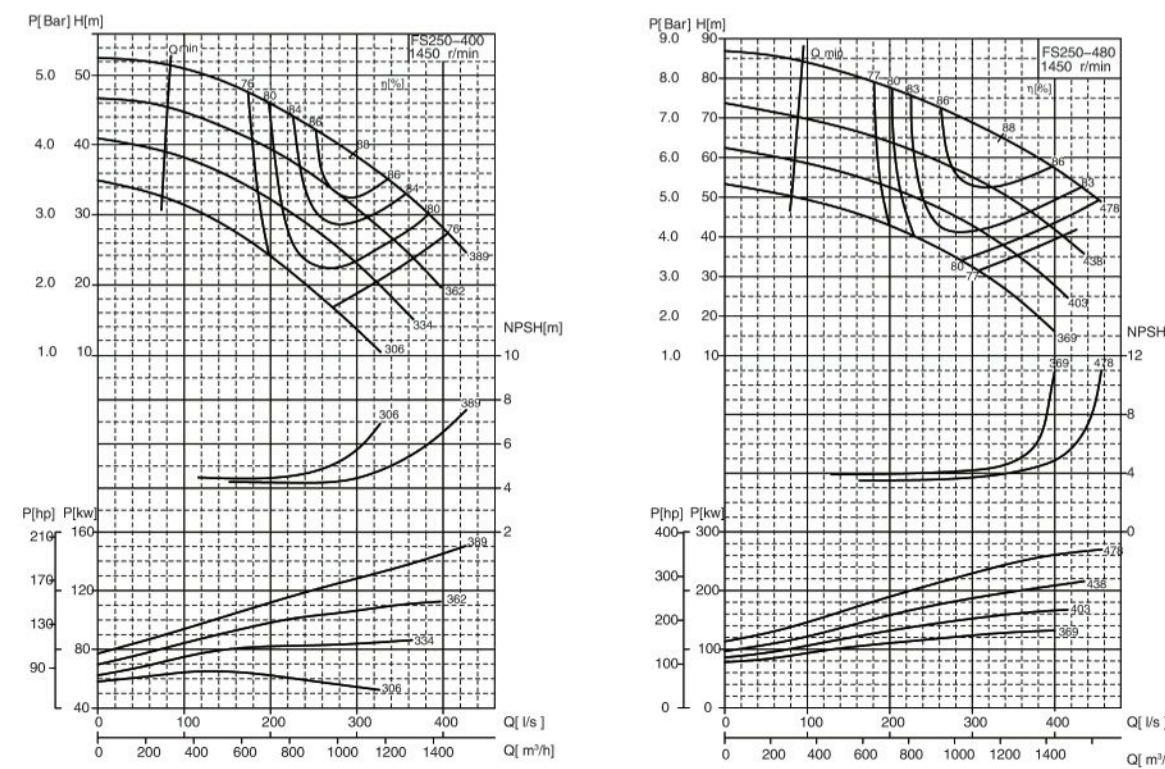
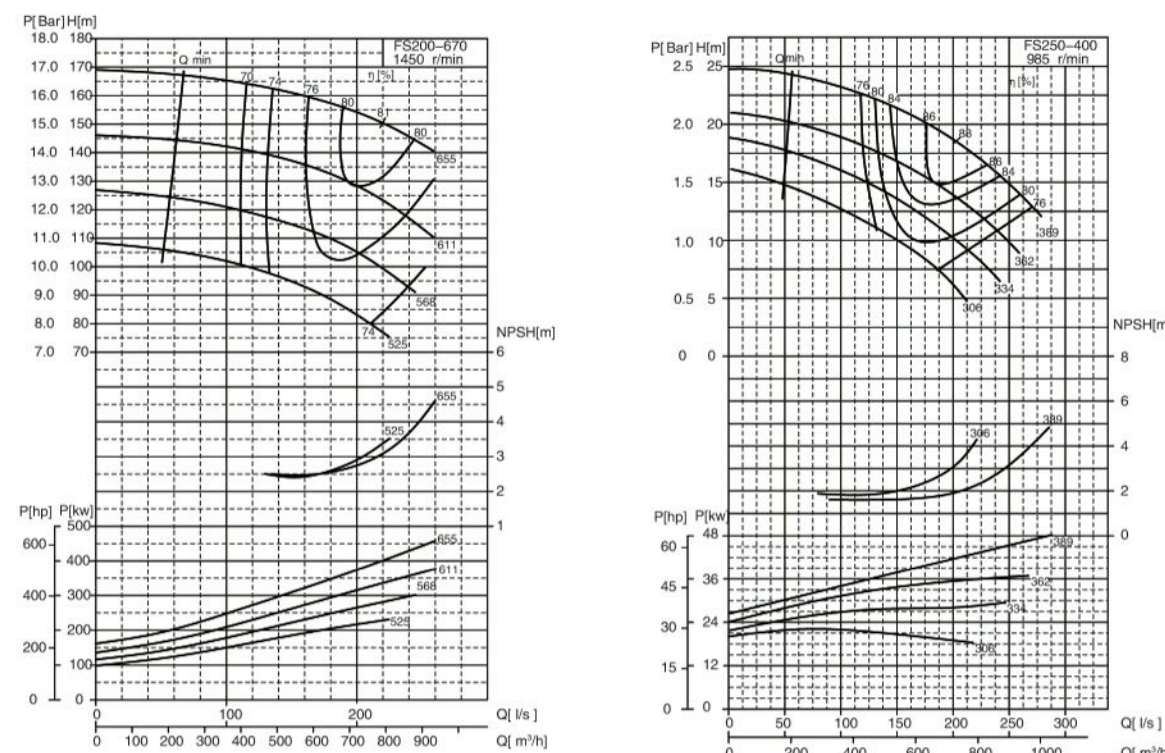

- FS
- FS80
- FS100
- FS125
- FS150
- FS200
- FS250
- FS300
- FS350
- FS400
- FS450
- FS500
- FS600
- FS700
- FS800
- FS900
- FS1000
- FS1100
- FS1200

DOUBLE SUCTION CENTRIFUGAL PUMP

FS SERIES / 单级双吸离心泵
FS系列

VII、PERFORMANCE CURVE CHART 性能曲线图

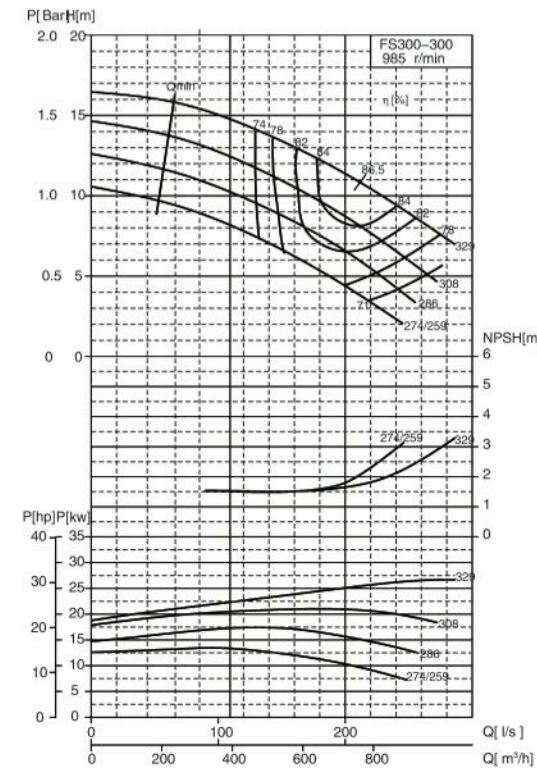
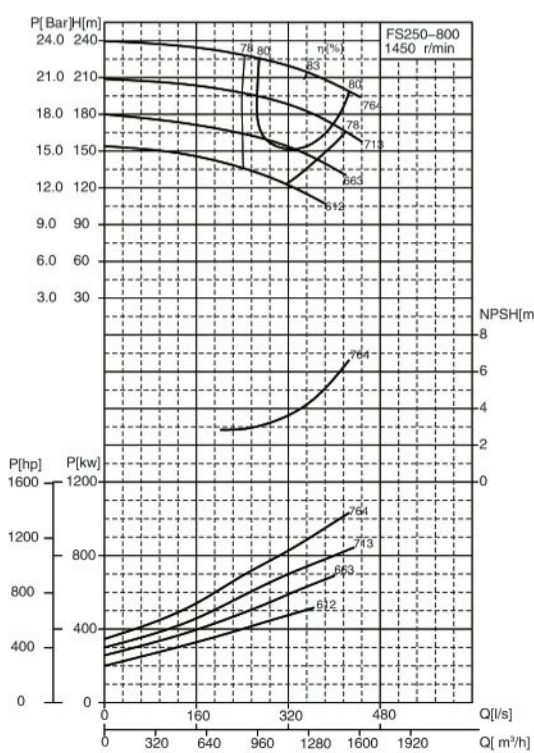
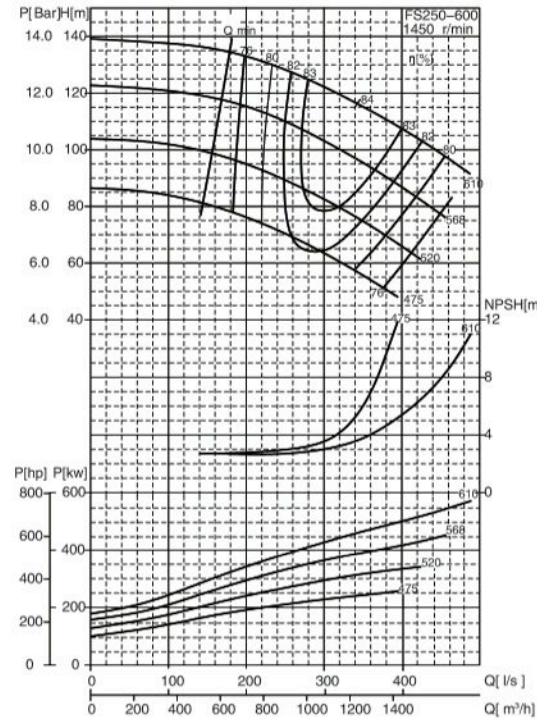
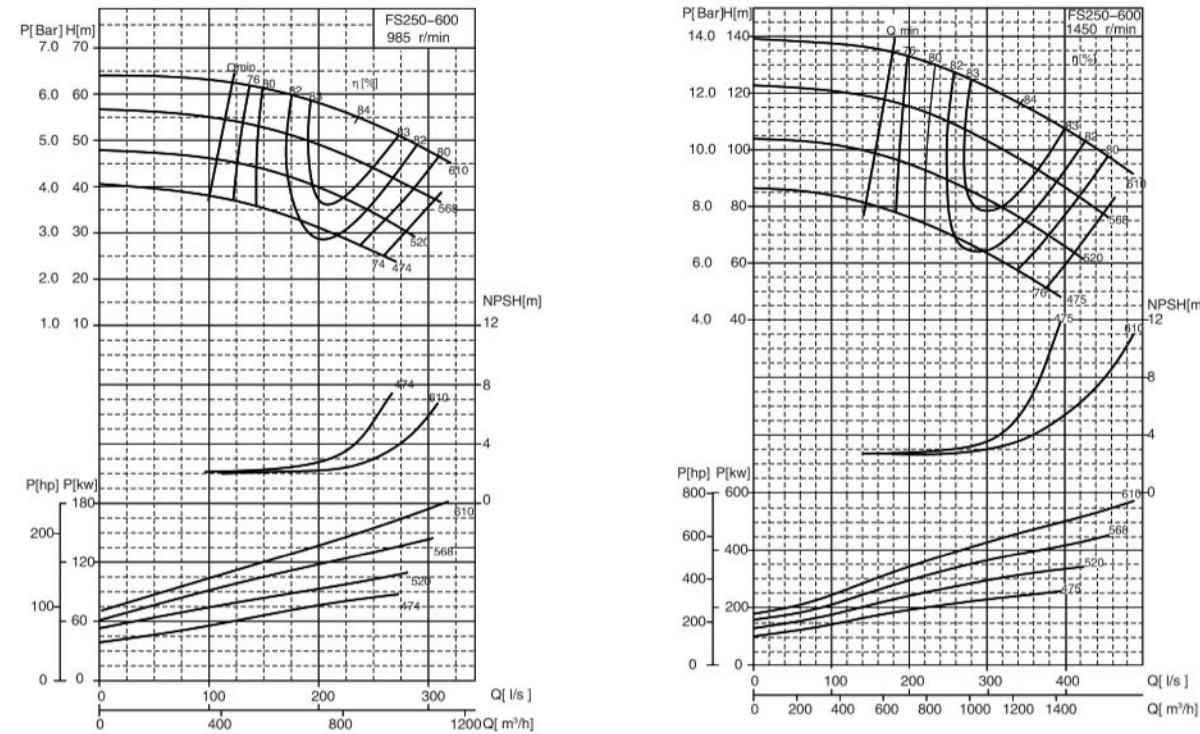

DOUBLE SUCTION CENTRIFUGAL PUMP

FS SERIES / 单级双吸离心泵
FS系列

VII、PERFORMANCE CURVE CHART 性能曲线图

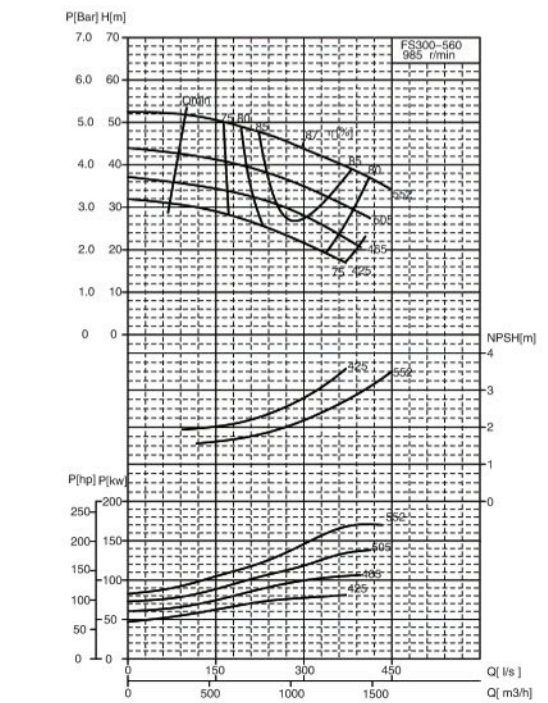
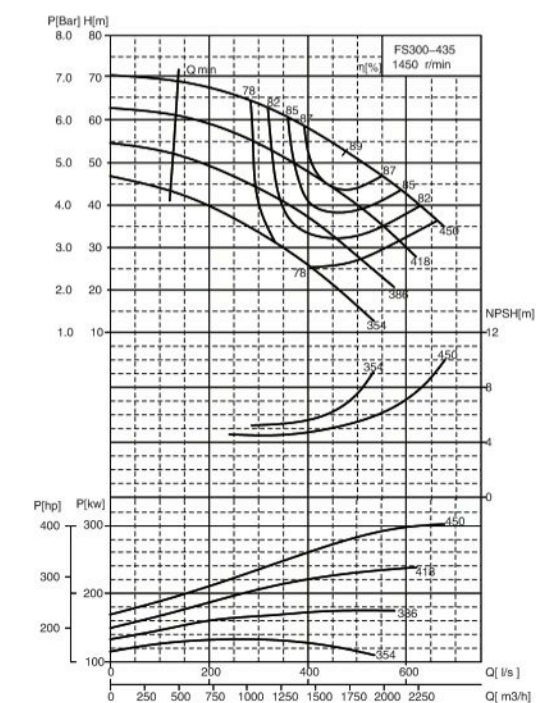
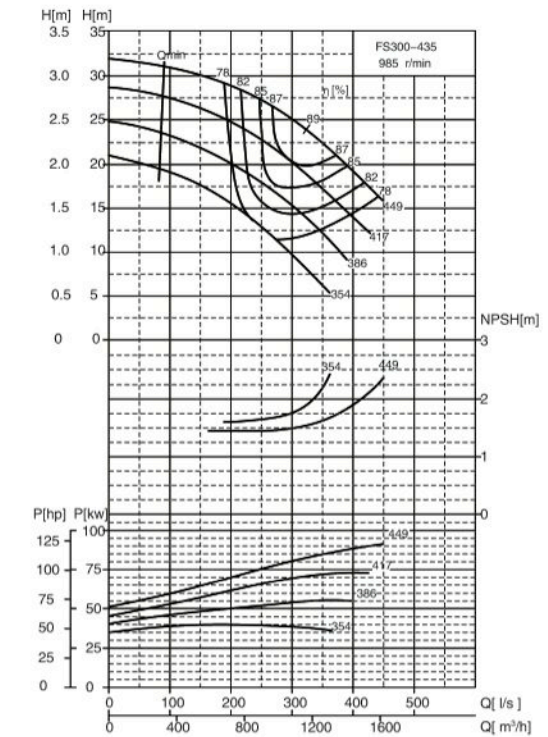
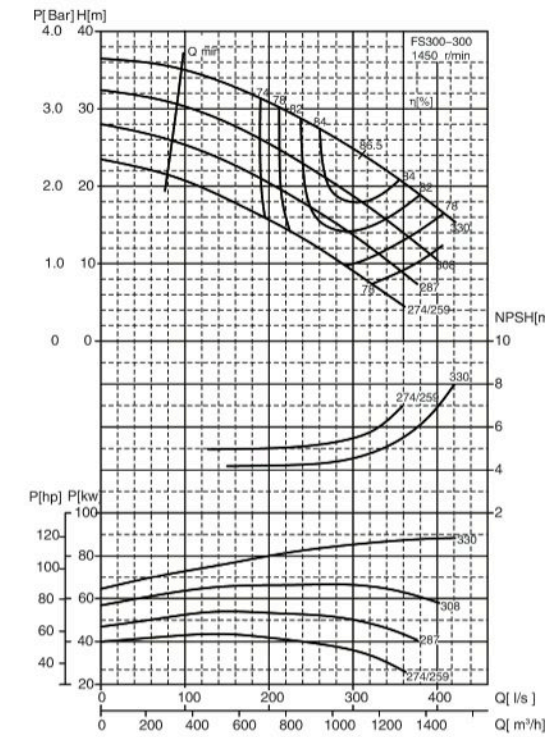

- FS
- FS80
- FS100
- FS125
- FS150
- FS200
- FS250
- FS300
- FS350
- FS400
- FS450
- FS500
- FS600
- FS700
- FS800
- FS900
- FS1000
- FS1100
- FS1200

DOUBLE SUCTION CENTRIFUGAL PUMP

FS SERIES / 单级双吸离心泵
FS系列

VII、PERFORMANCE CURVE CHART 性能曲线图

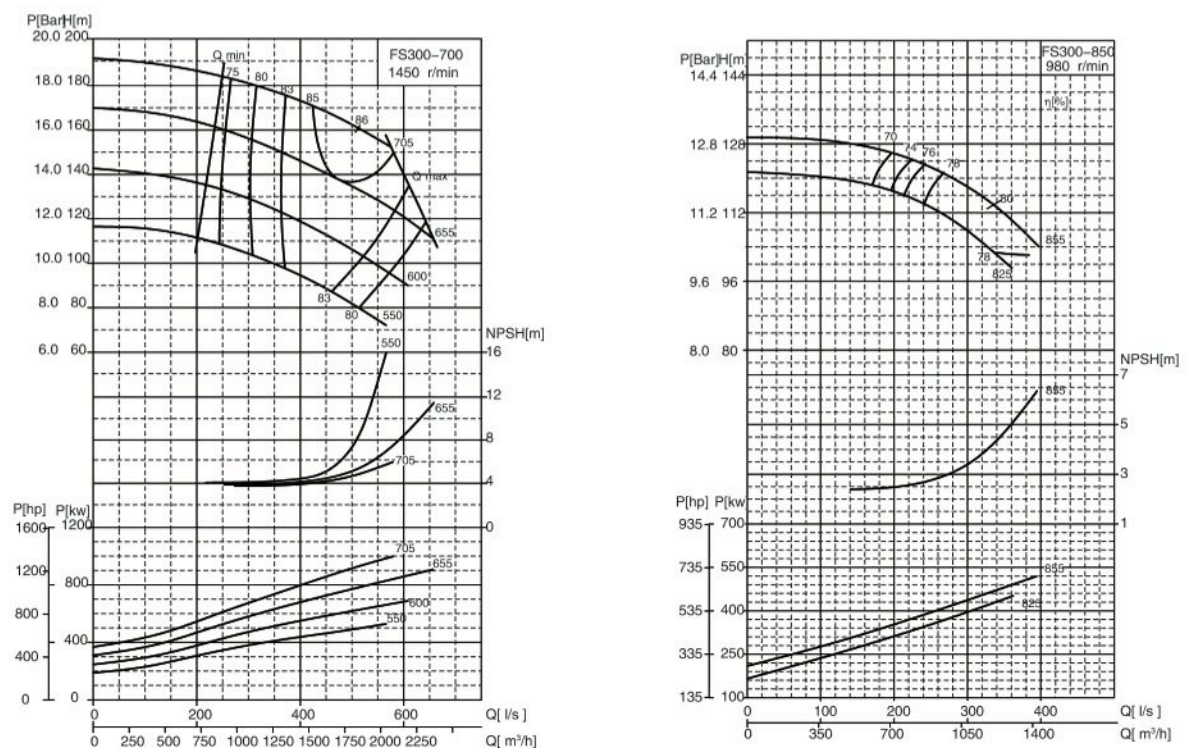
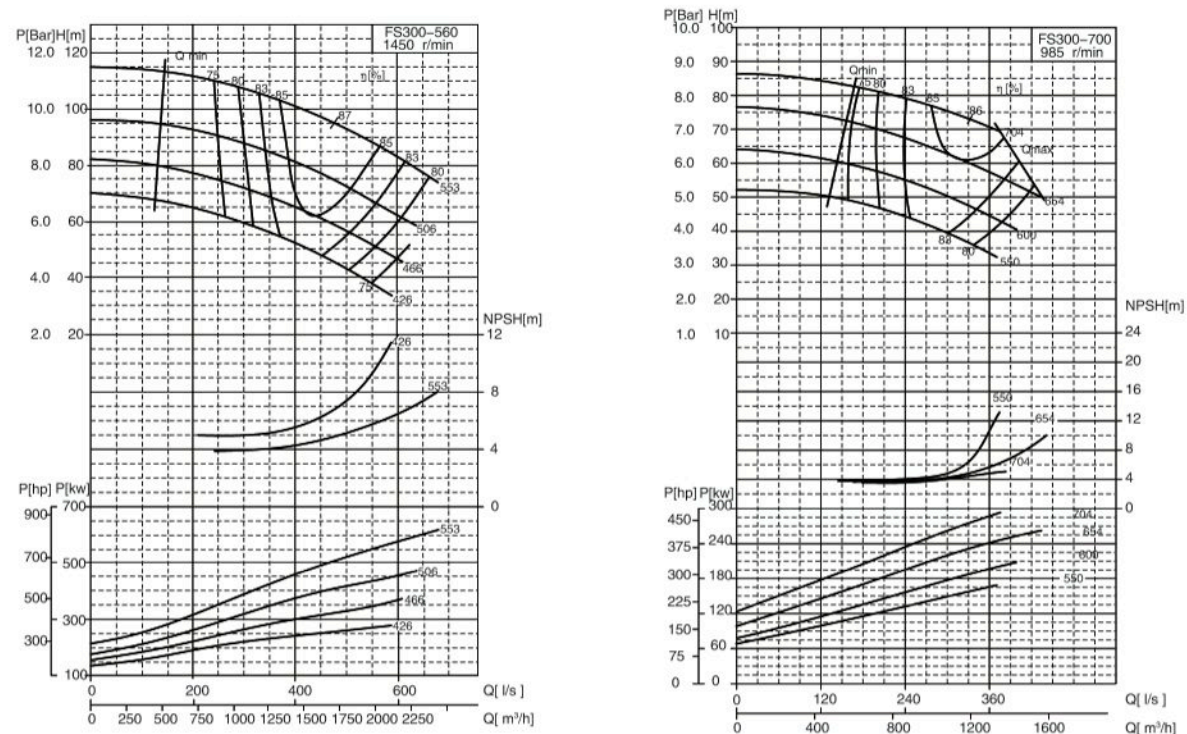

DOUBLE SUCTION CENTRIFUGAL PUMP

FS SERIES / 单级双吸离心泵
FS系列

VII、PERFORMANCE CURVE CHART 性能曲线图

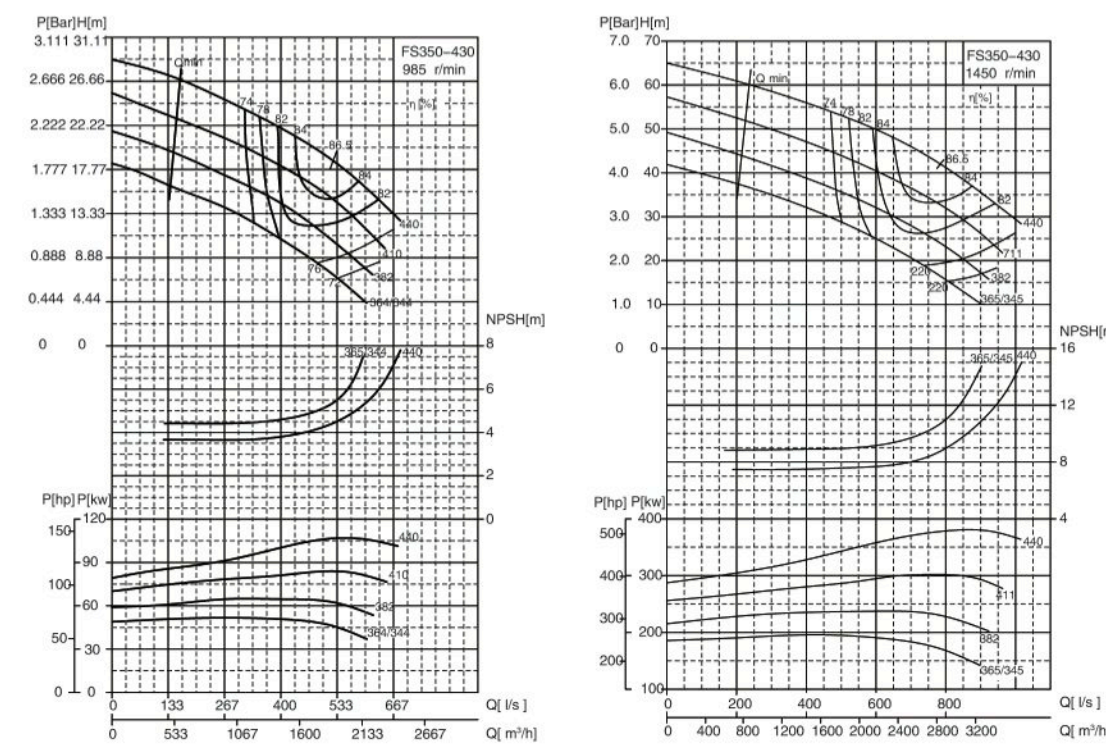
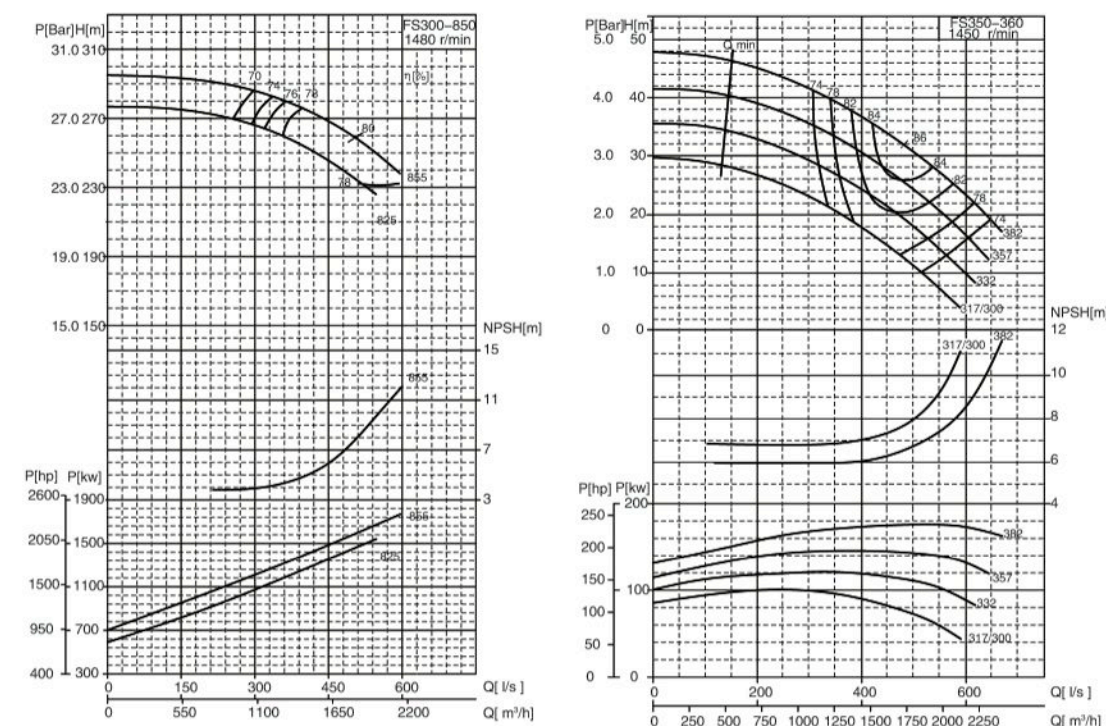

FS

FS80

FS100

FS125

FS150

FS200

FS250

FS300

FS350

FS400

FS450

FS500

FS600

FS700

FS800

FS900

FS1000

FS1100

FS1200

DOUBLE SUCTION CENTRIFUGAL PUMP

FS SERIES / 单级双吸离心泵
FS系列

VII、PERFORMANCE CURVE CHART 性能曲线图

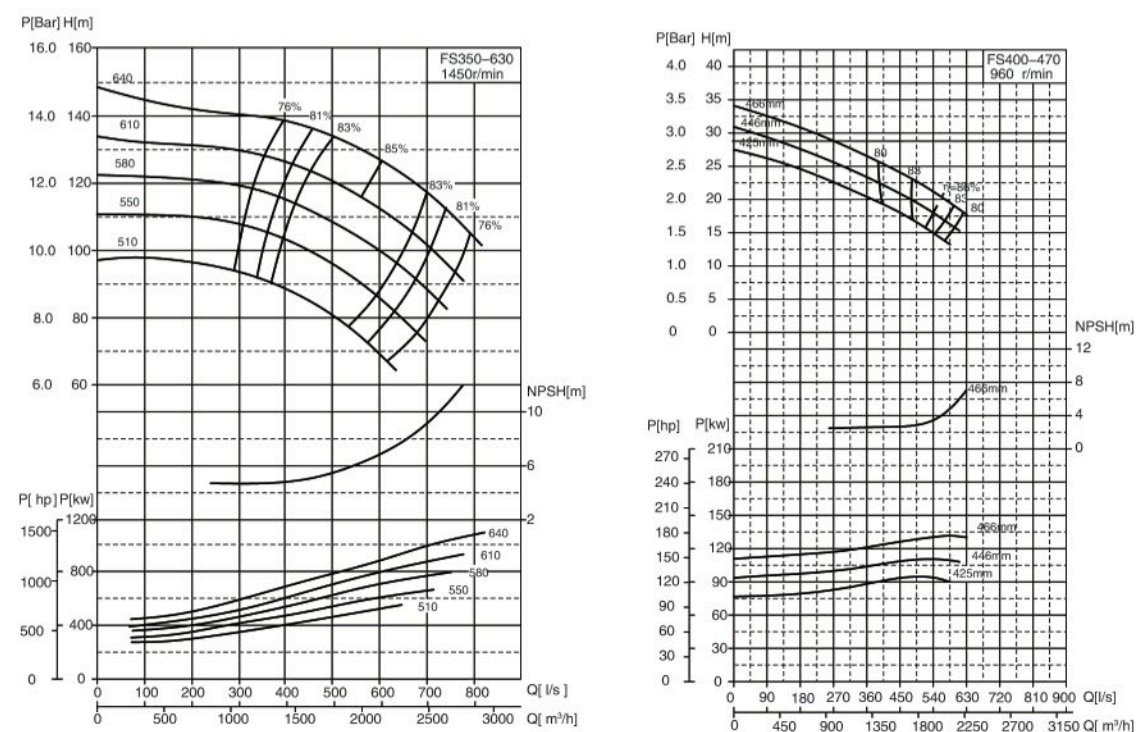
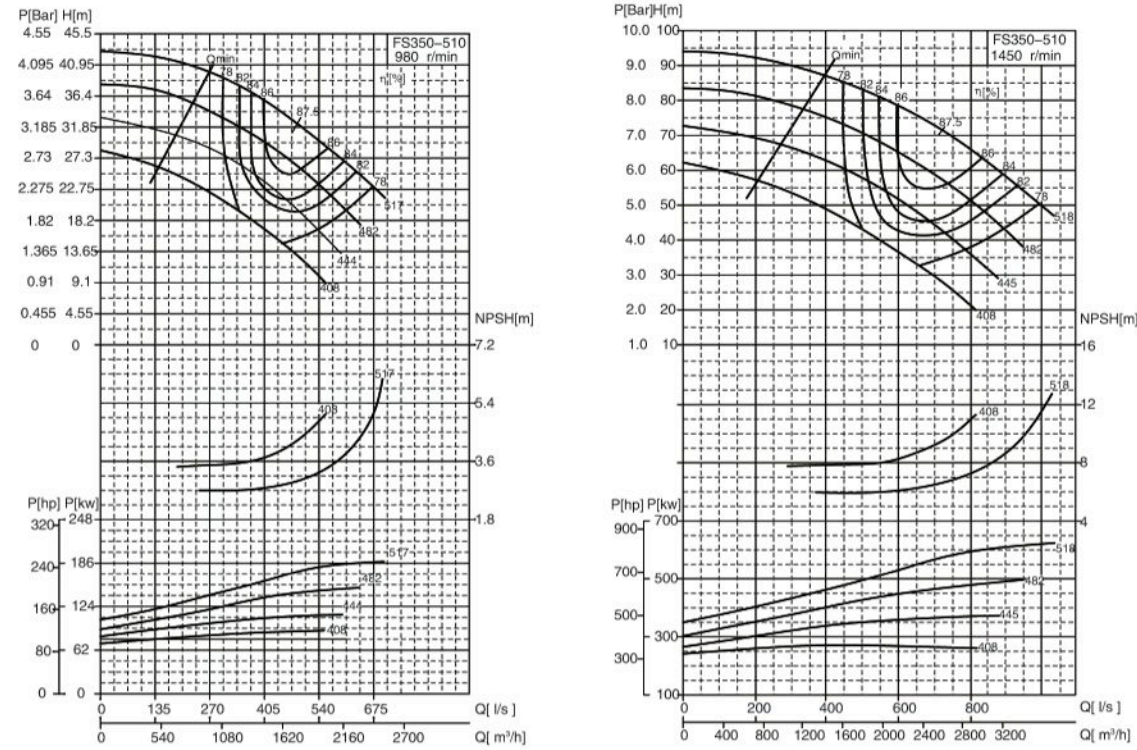

DOUBLE SUCTION CENTRIFUGAL PUMP

FS SERIES / 单级双吸离心泵
FS系列

VII、PERFORMANCE CURVE CHART 性能曲线图

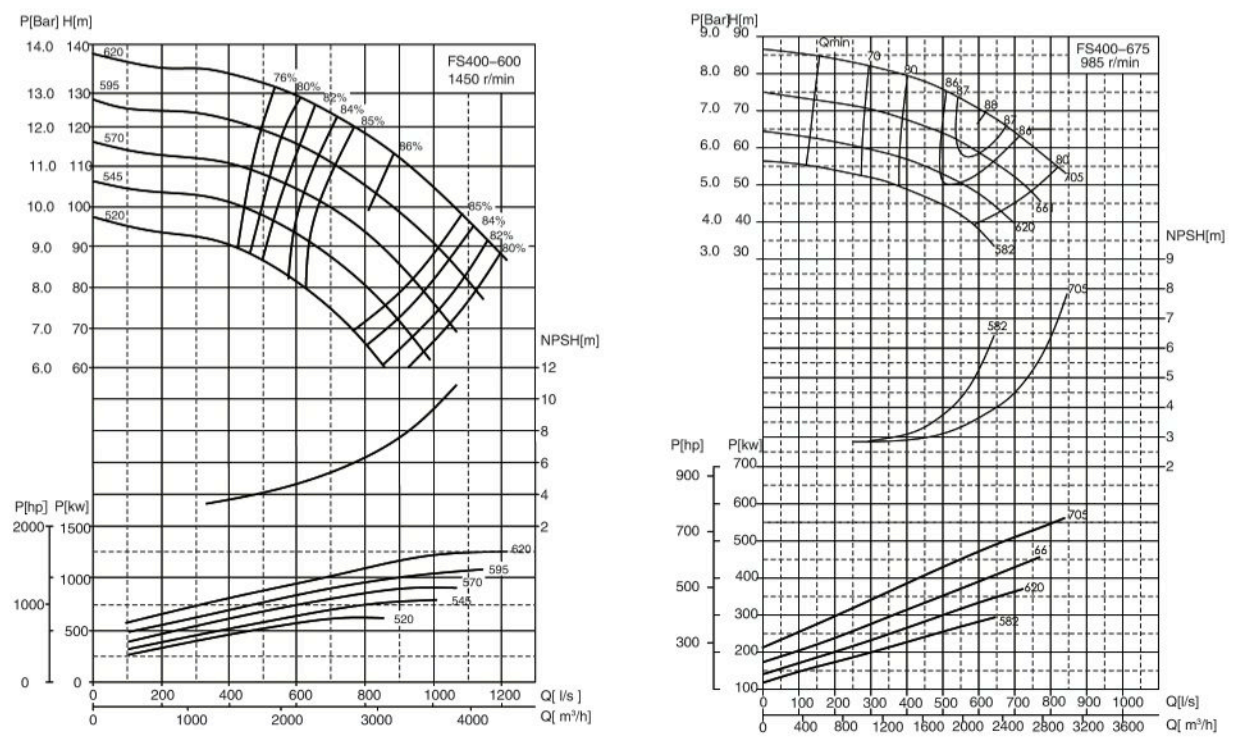
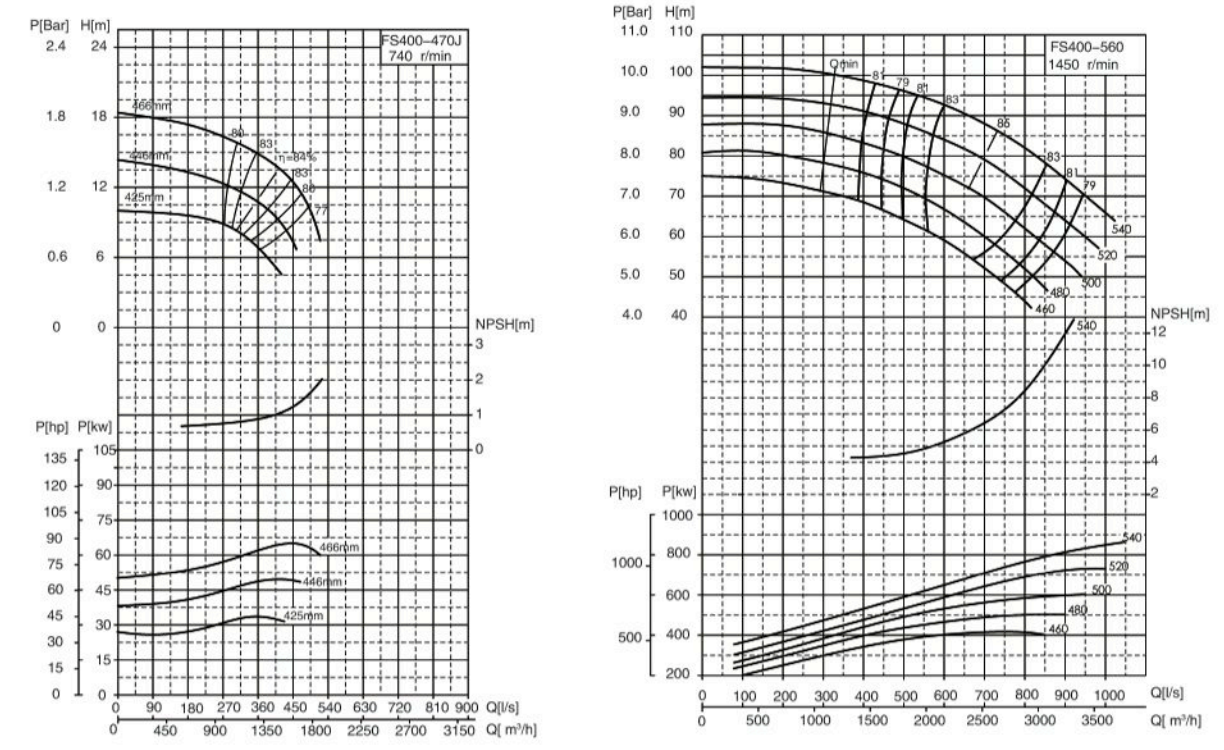

FS

FS80

FS100

FS125

FS150

FS200

FS250

FS300

FS350

FS400

FS450

FS500

FS600

FS700

FS800

FS900

FS1000

FS1100

FS1200

DOUBLE SUCTION CENTRIFUGAL PUMP

FS SERIES / 单级双吸离心泵
FS系列

VII、PERFORMANCE CURVE CHART 性能曲线图

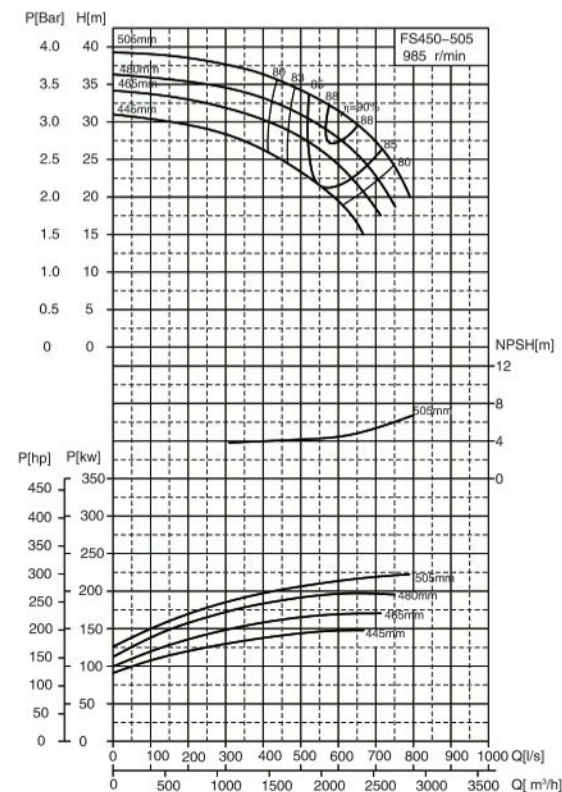
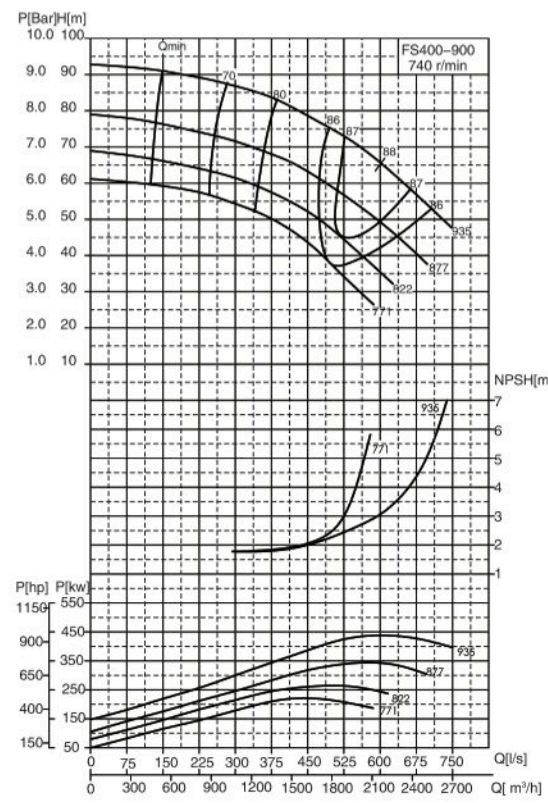
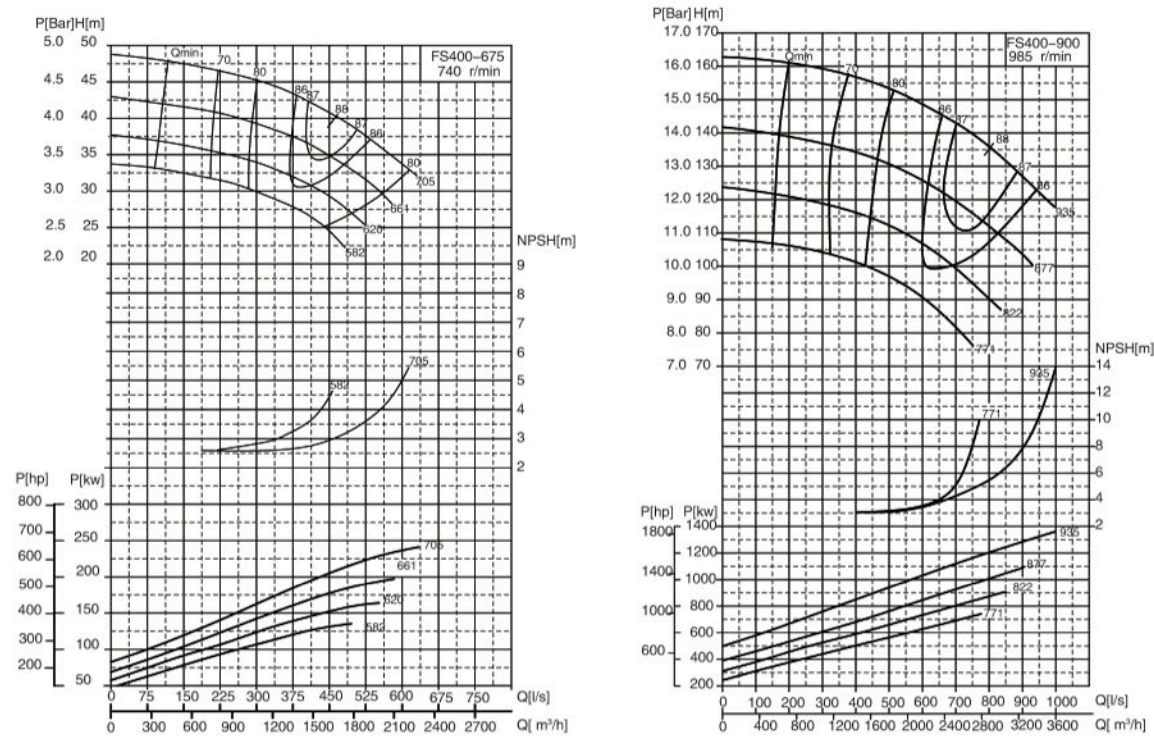

DOUBLE SUCTION CENTRIFUGAL PUMP

FS SERIES / 单级双吸离心泵
FS系列

VII、PERFORMANCE CURVE CHART 性能曲线图

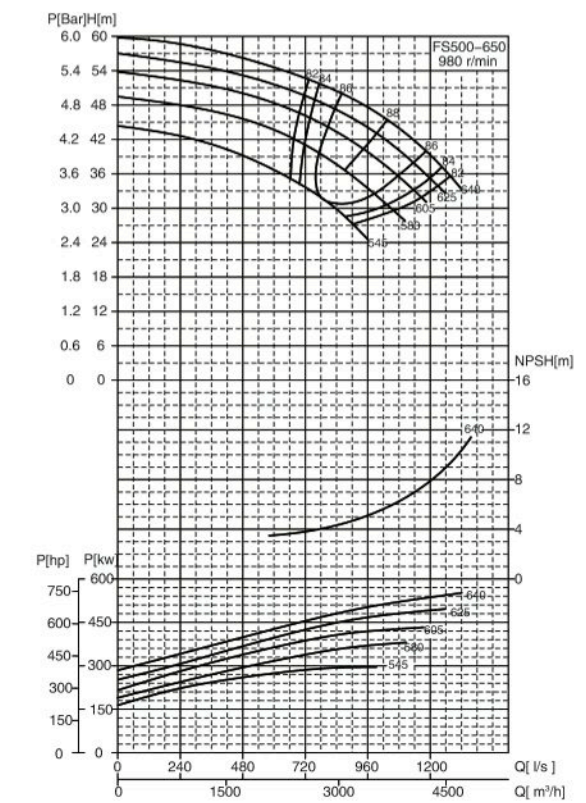
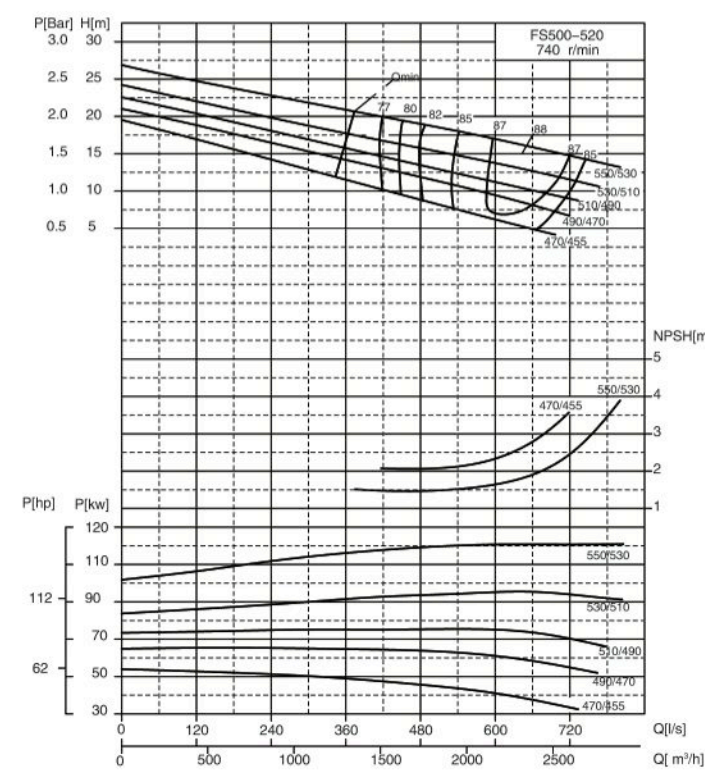
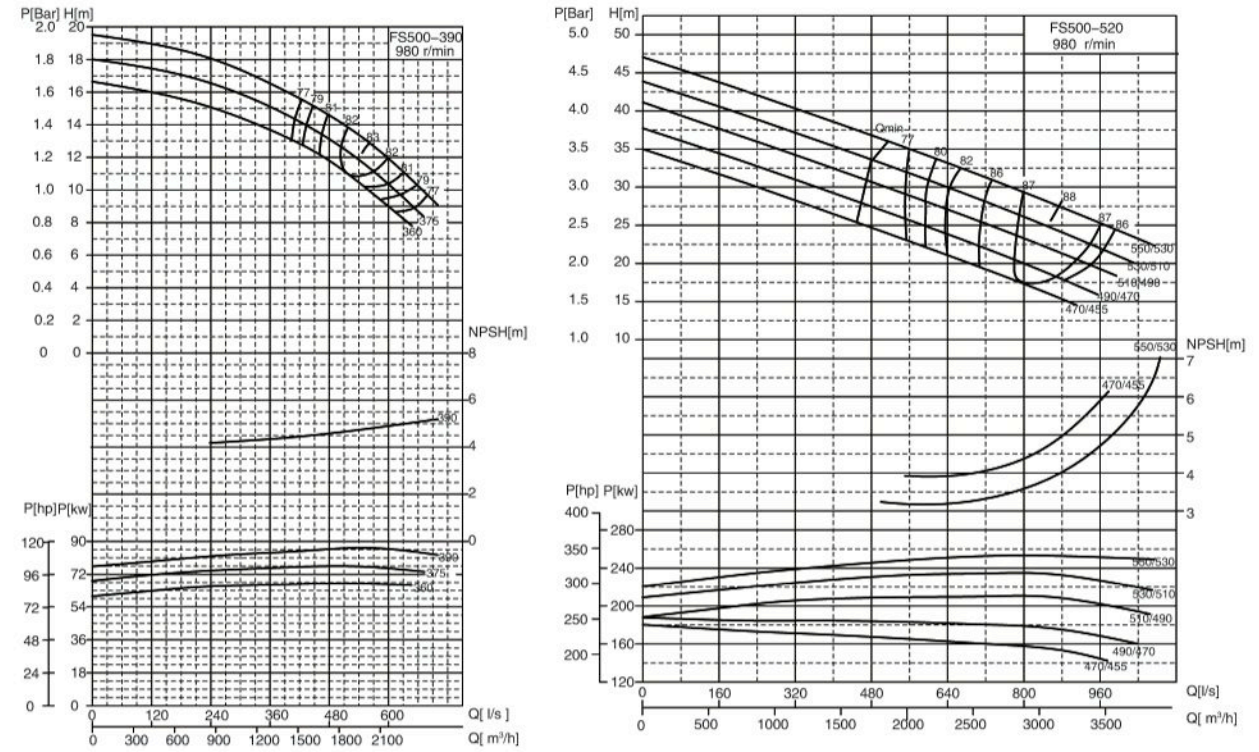

FS

FS80

FS100

FS125

FS150

FS200

FS250

FS300

FS350

FS400

FS450

FS500

FS600

FS700

FS800

FS900

FS1000

FS1100

FS1200

DOUBLE SUCTION CENTRIFUGAL PUMP

FS SERIES / 单级双吸离心泵
FS系列

VII、PERFORMANCE CURVE CHART 性能曲线图

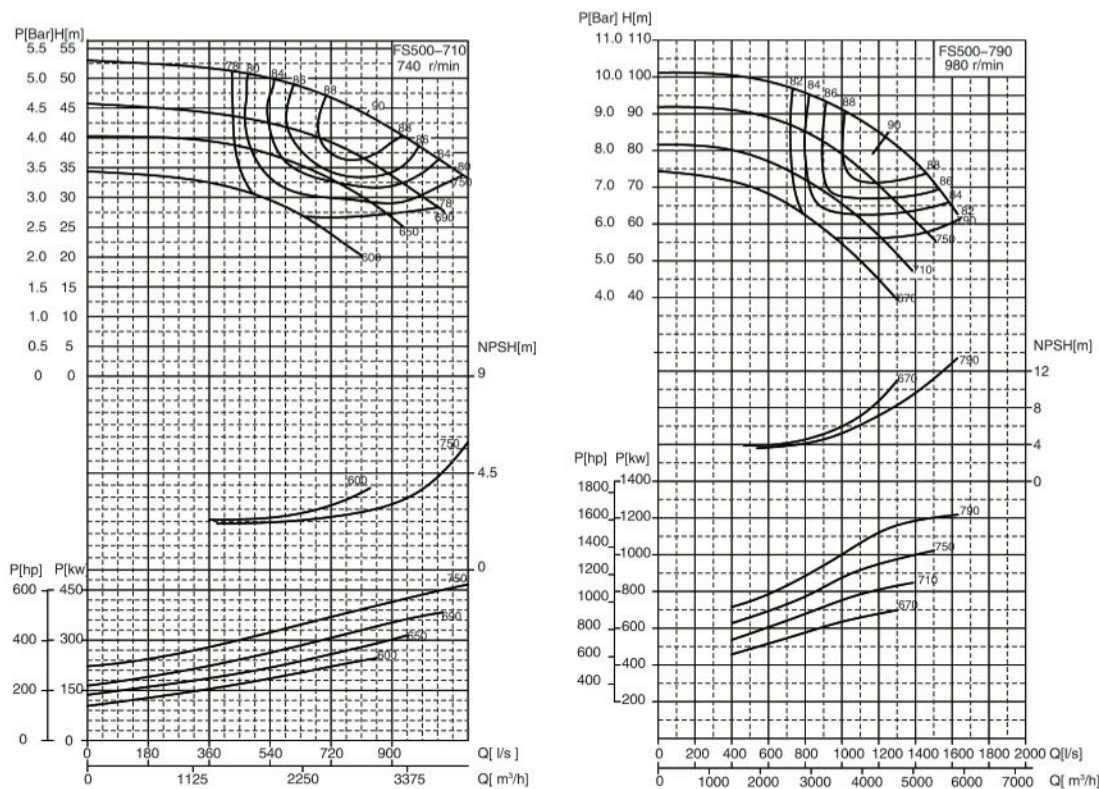
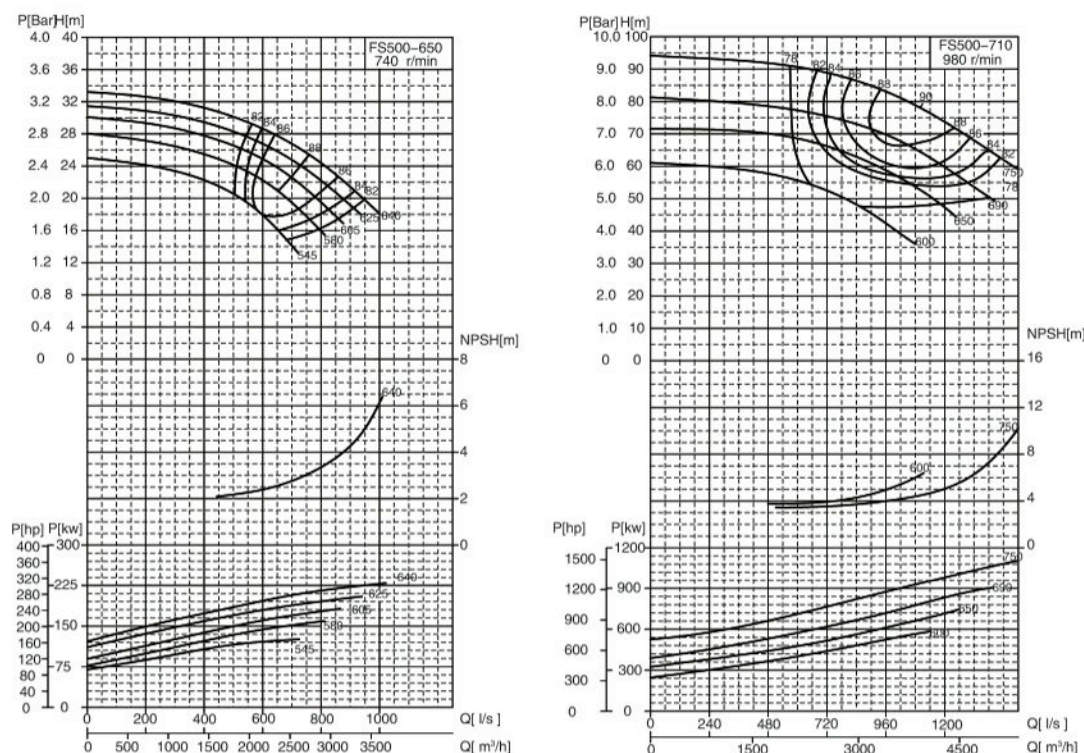

DOUBLE SUCTION CENTRIFUGAL PUMP

FS SERIES / 单级双吸离心泵
FS系列

VII、PERFORMANCE CURVE CHART 性能曲线图

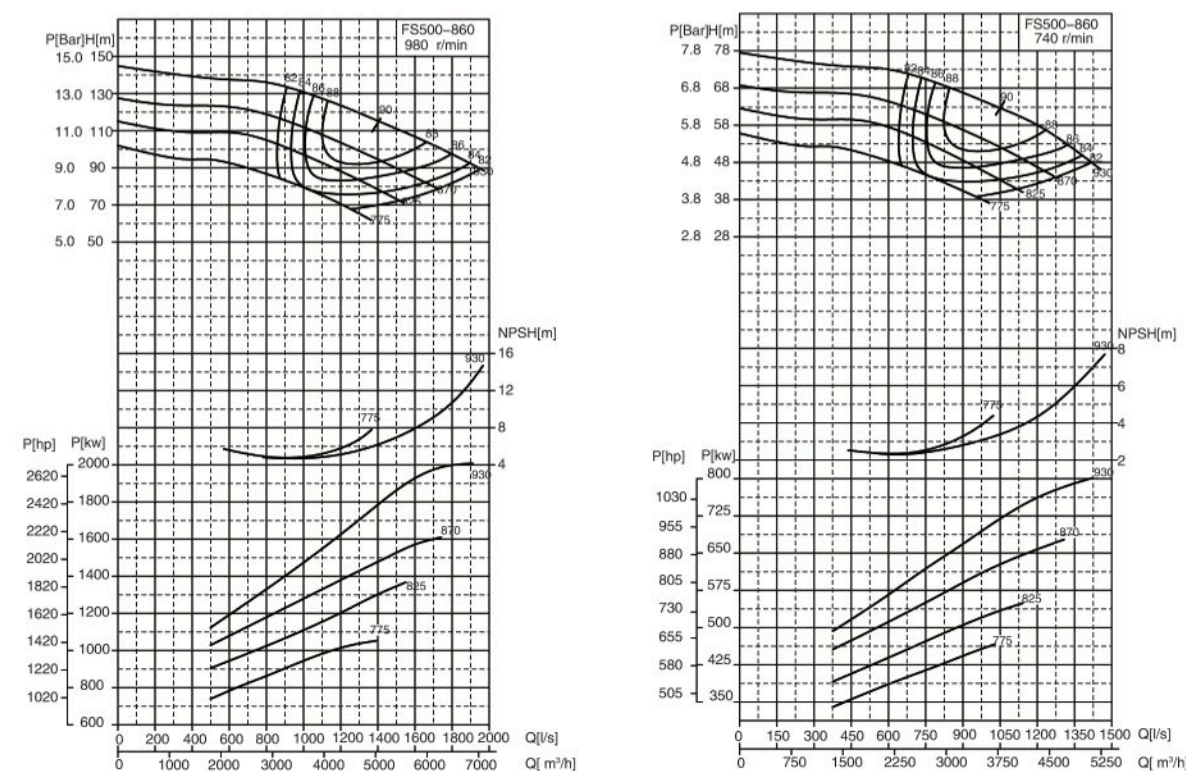
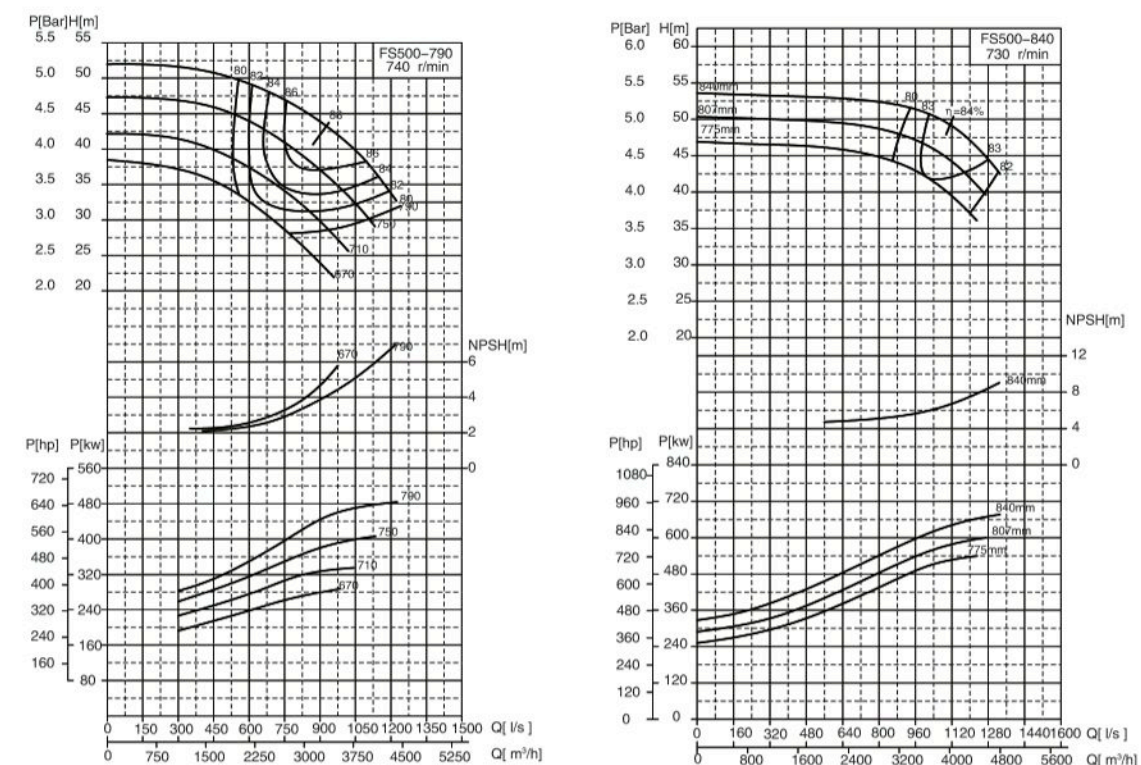

- FS
- FS80
- FS100
- FS125
- FS150
- FS200
- FS250
- FS300
- FS350
- FS400
- FS450
- FS500
- FS600
- FS700
- FS800
- FS900
- FS1000
- FS1100
- FS1200

DOUBLE SUCTION CENTRIFUGAL PUMP

FS SERIES / 单级双吸离心泵
FS系列

VII、PERFORMANCE CURVE CHART 性能曲线图

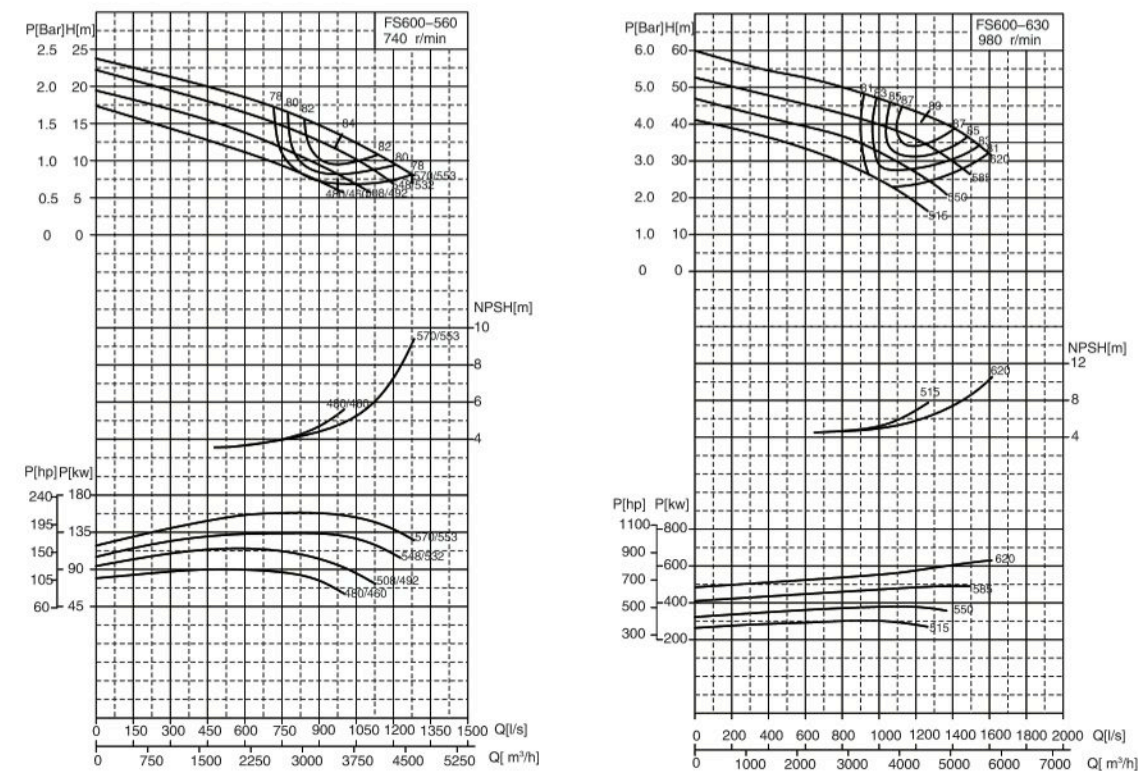
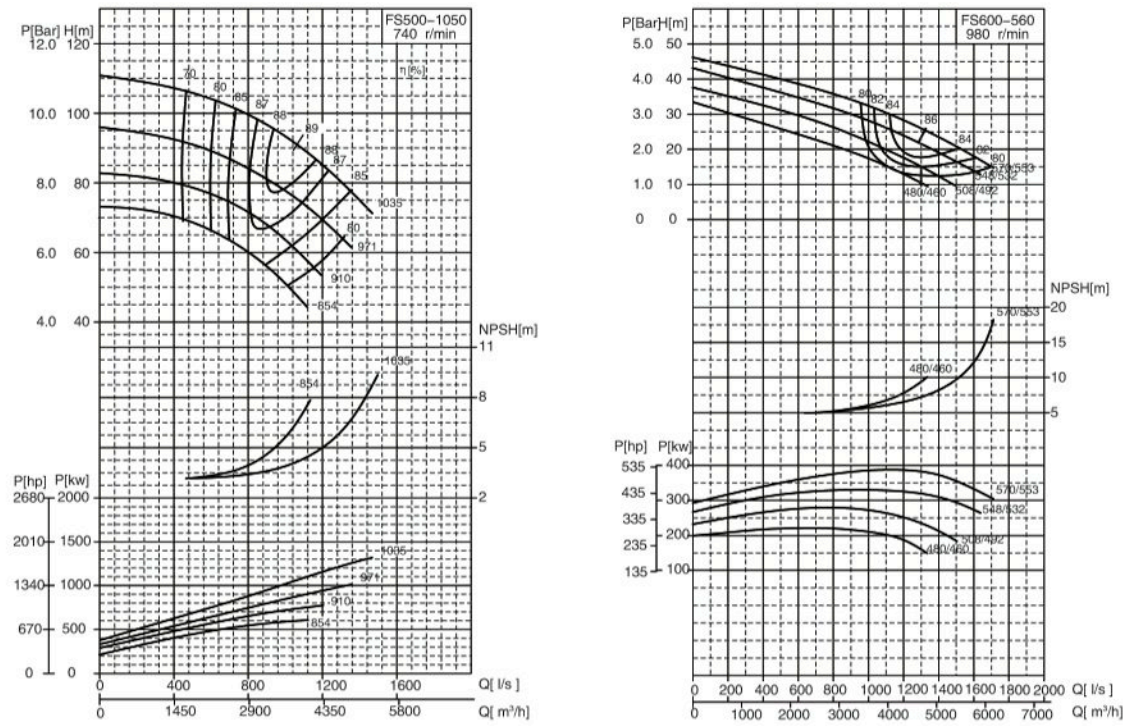

DOUBLE SUCTION CENTRIFUGAL PUMP

FS SERIES / 单级双吸离心泵
FS系列

VII、PERFORMANCE CURVE CHART 性能曲线图

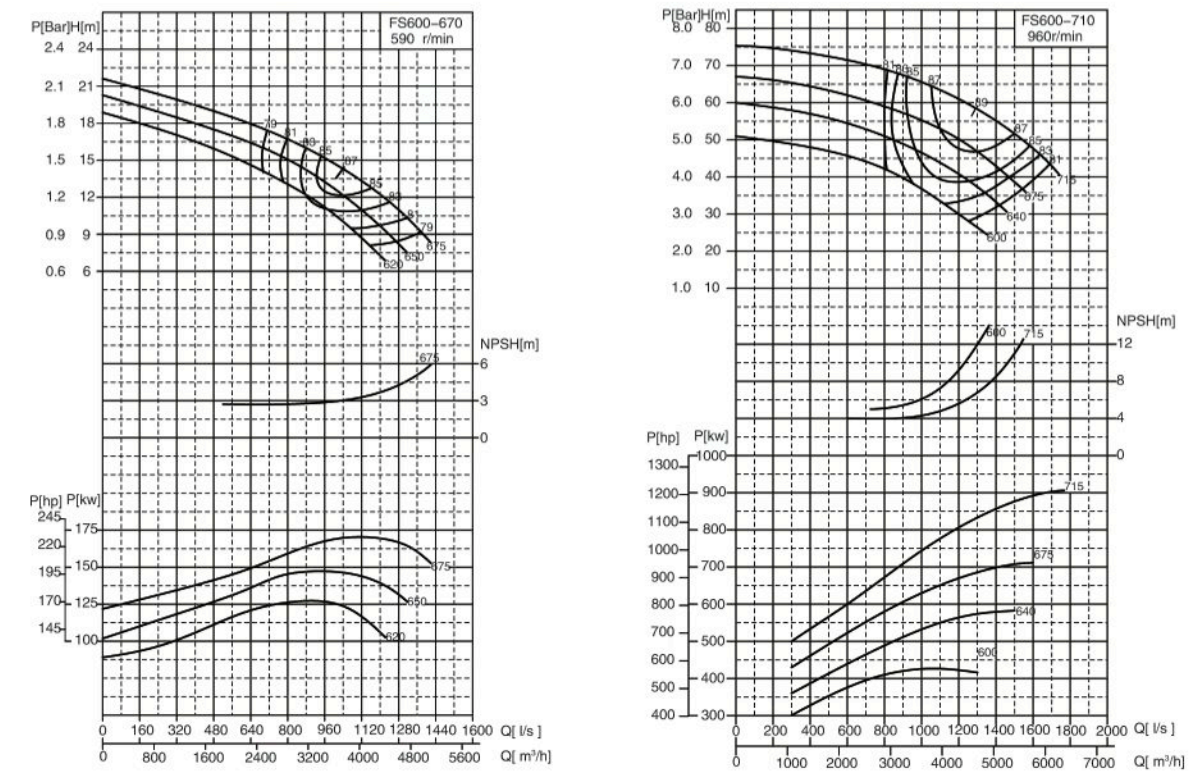
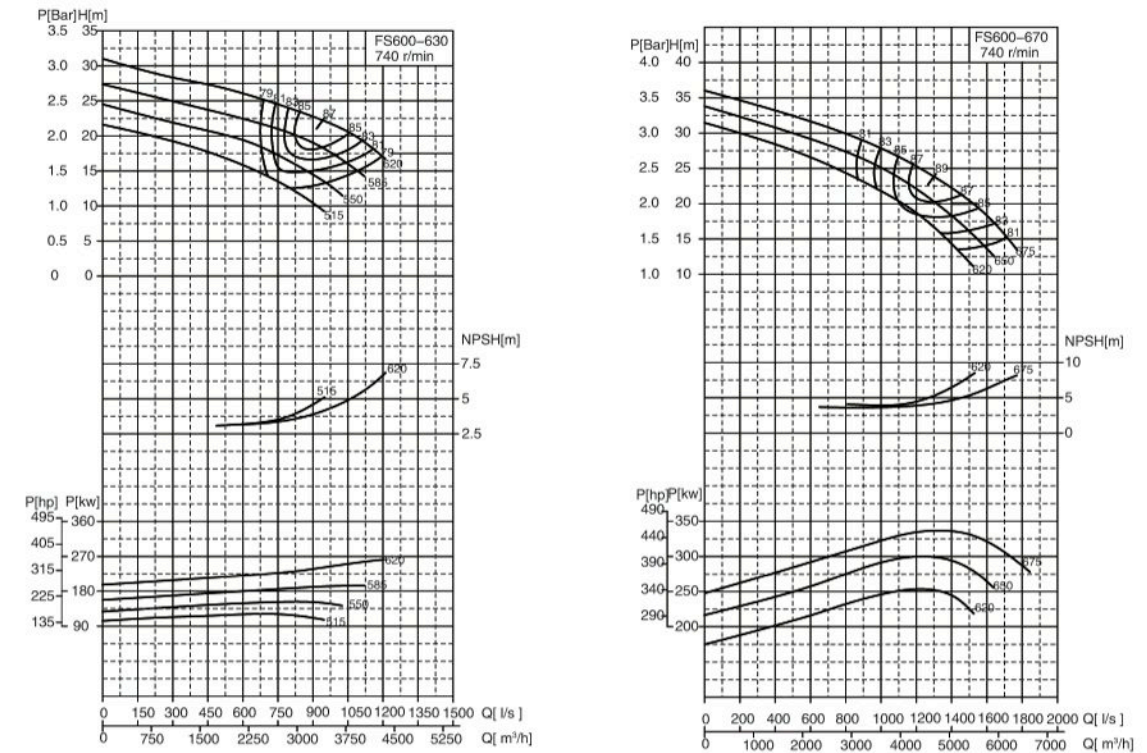

FS

FS80

FS100

FS125

FS150

FS200

FS250

FS300

FS350

FS400

FS450

FS500

FS600

FS700

FS800

FS900

FS1000

FS1100

FS1200

DOUBLE SUCTION CENTRIFUGAL PUMP

FS SERIES / 单级双吸离心泵
FS系列

VII、PERFORMANCE CURVE CHART 性能曲线图

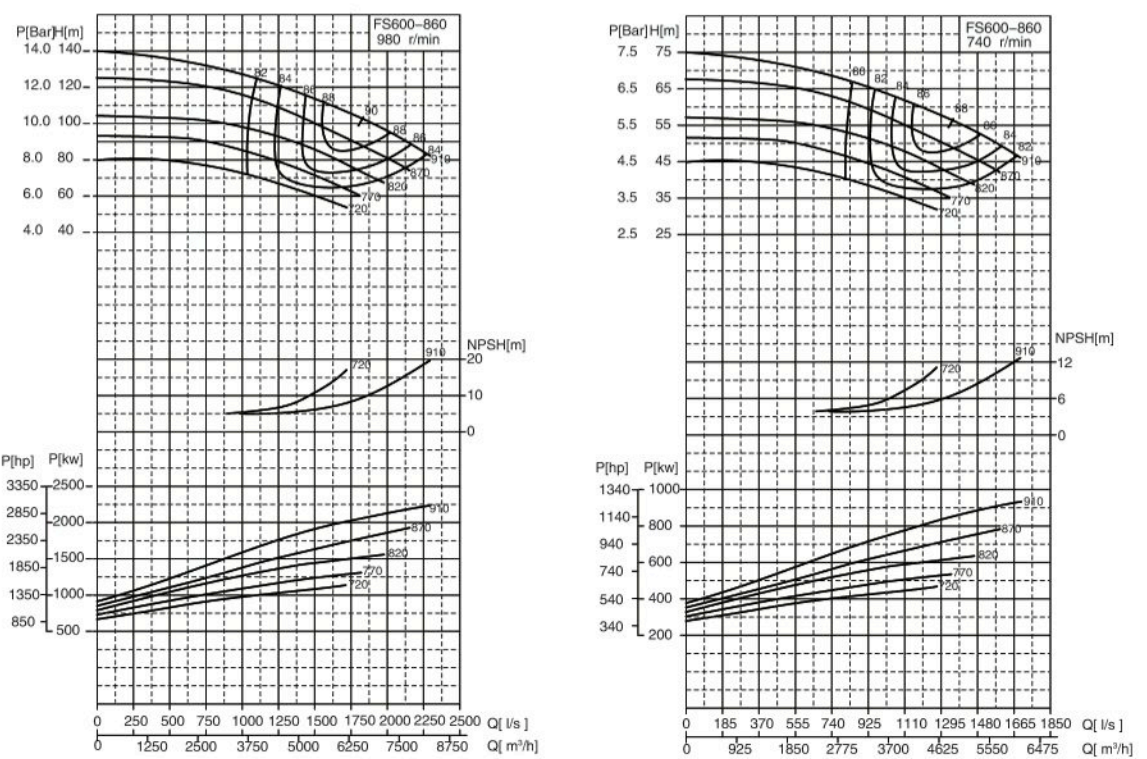
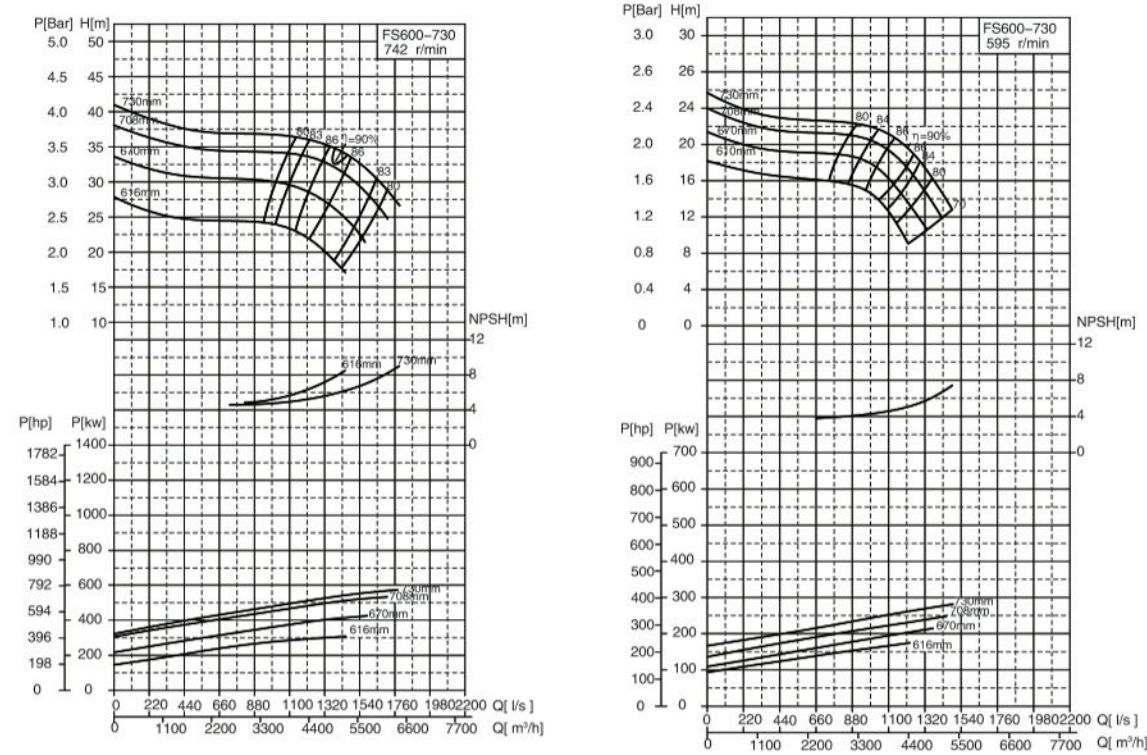

DOUBLE SUCTION CENTRIFUGAL PUMP

FS SERIES / 单级双吸离心泵
FS系列

VII、PERFORMANCE CURVE CHART 性能曲线图

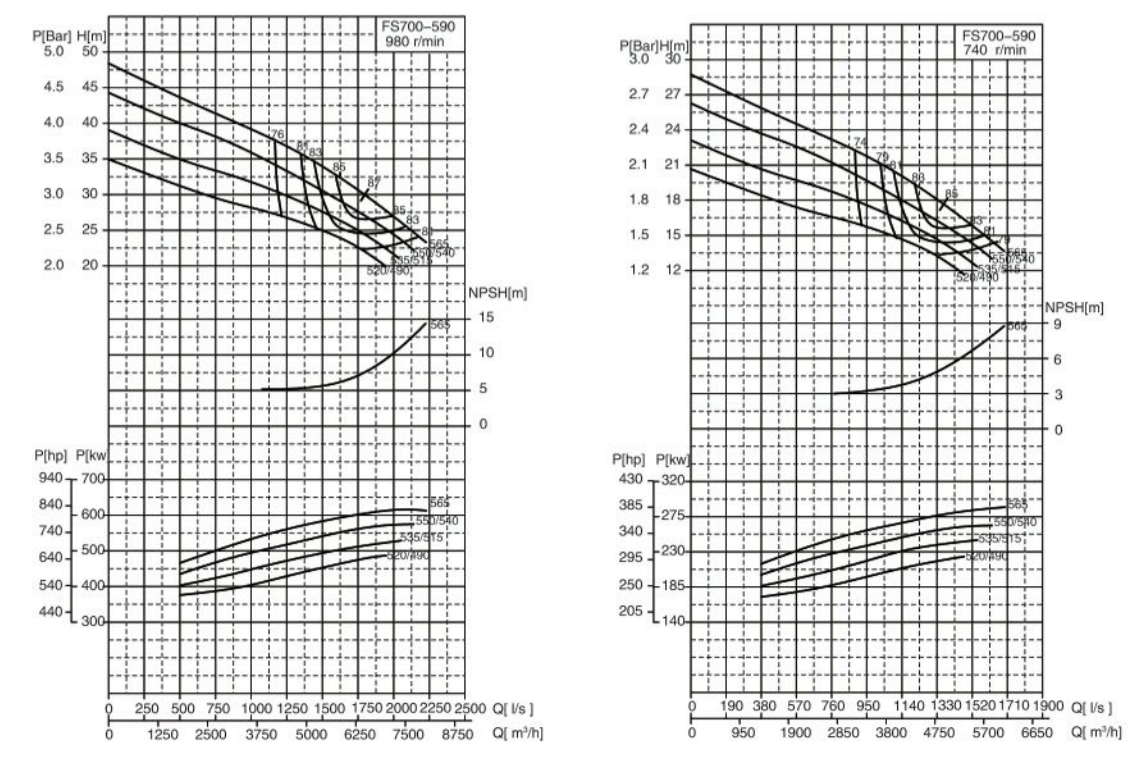
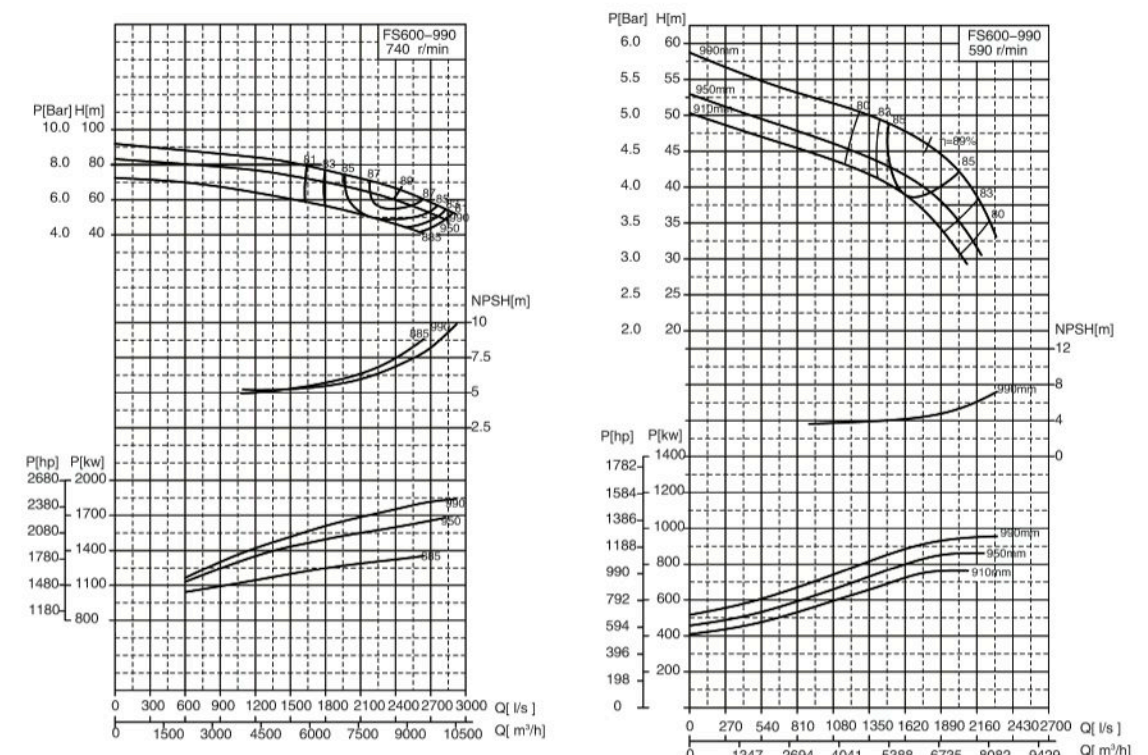

- FS
- FS80
- FS100
- FS125
- FS150
- FS200
- FS250
- FS300
- FS350
- FS400
- FS450
- FS500
- FS600
- FS700
- FS800
- FS900
- FS1000
- FS1100
- FS1200

DOUBLE SUCTION CENTRIFUGAL PUMP

FS SERIES / 单级双吸离心泵
FS系列

VII、PERFORMANCE CURVE CHART 性能曲线图

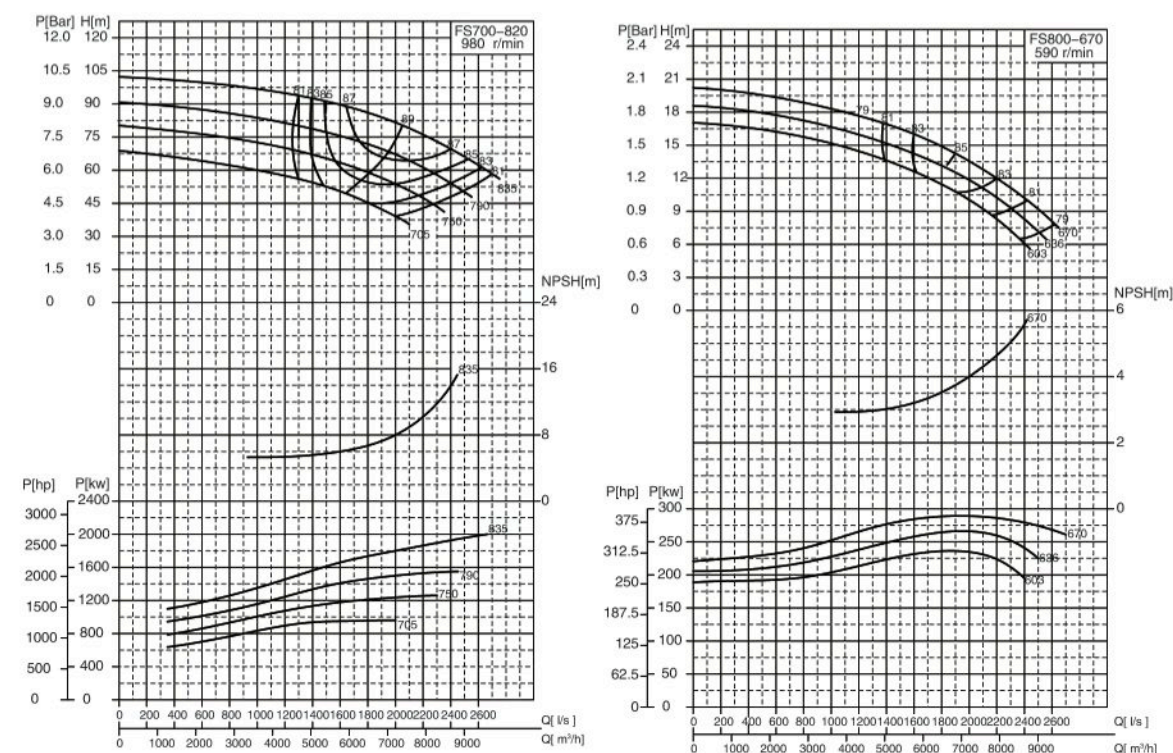
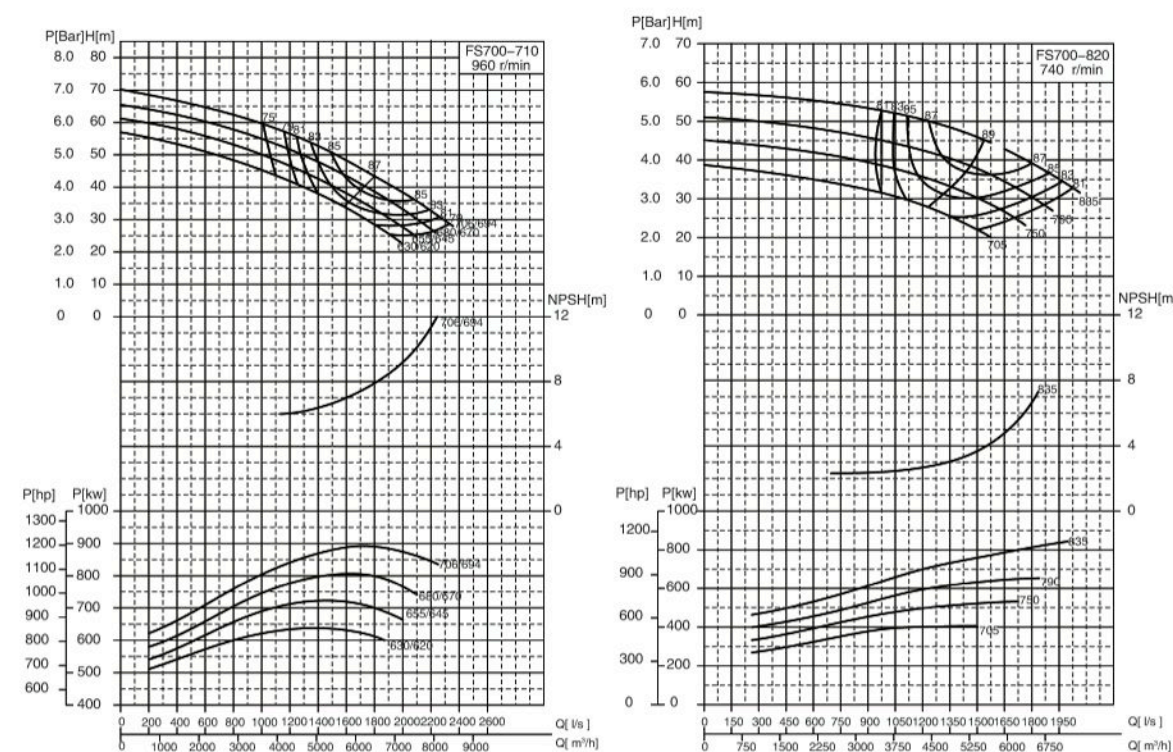

DOUBLE SUCTION CENTRIFUGAL PUMP

FS SERIES / 单级双吸离心泵
FS系列

VII、PERFORMANCE CURVE CHART 性能曲线图

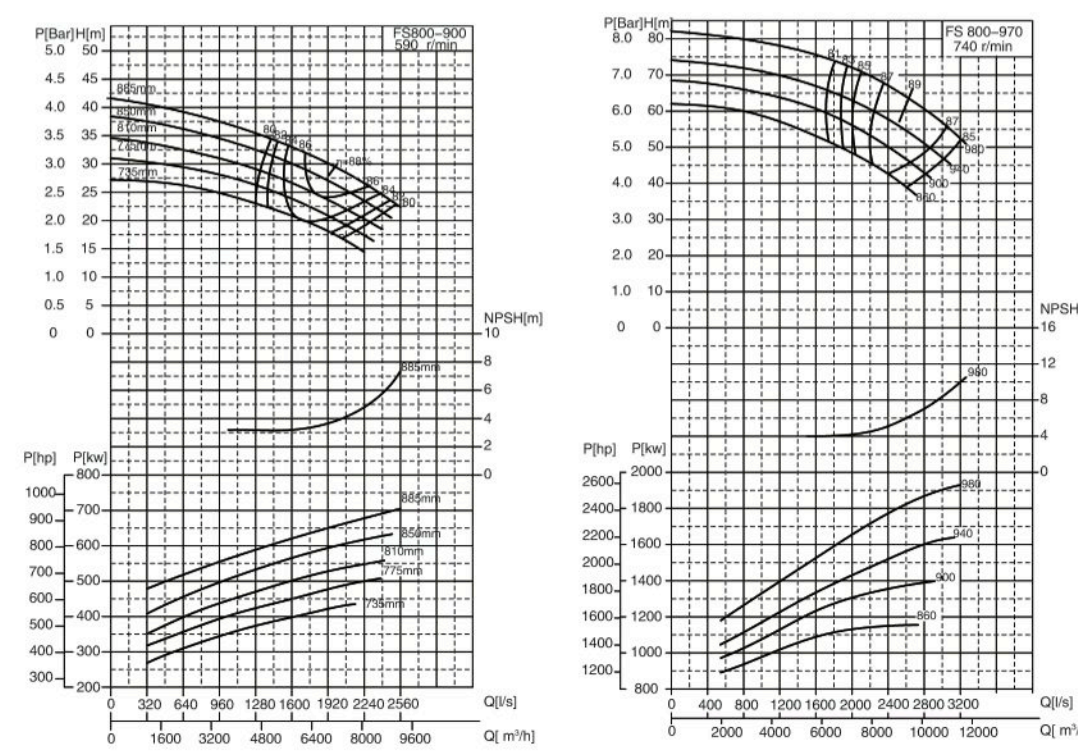
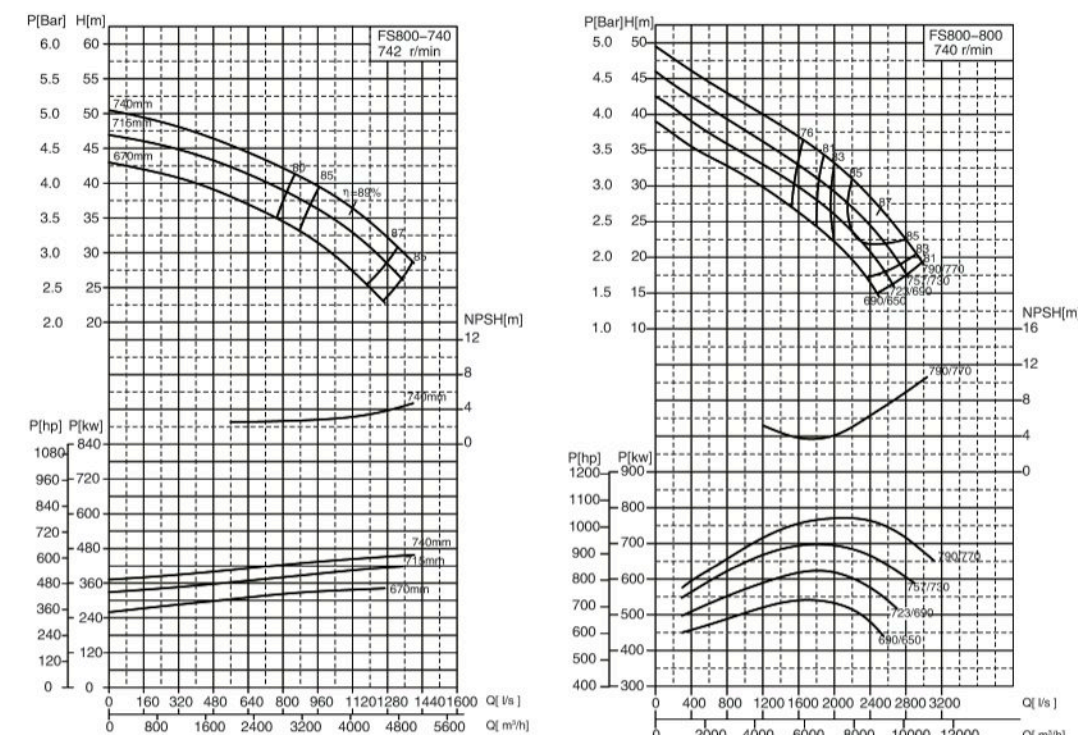

FS

FS80

FS100

FS125

FS150

FS200

FS250

FS300

FS350

FS400

FS450

FS500

FS600

FS700

FS800

FS900

FS1000

FS1100

FS1200

DOUBLE SUCTION CENTRIFUGAL PUMP

FS SERIES / 单级双吸离心泵
FS系列

VII、PERFORMANCE CURVE CHART 性能曲线图

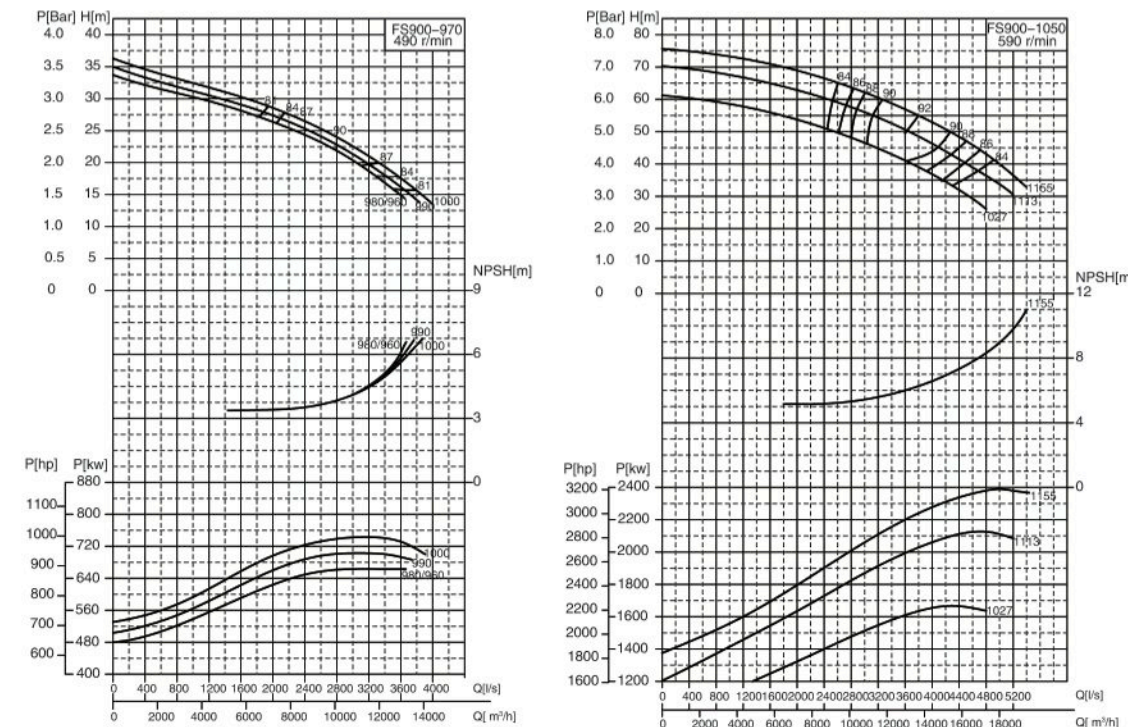
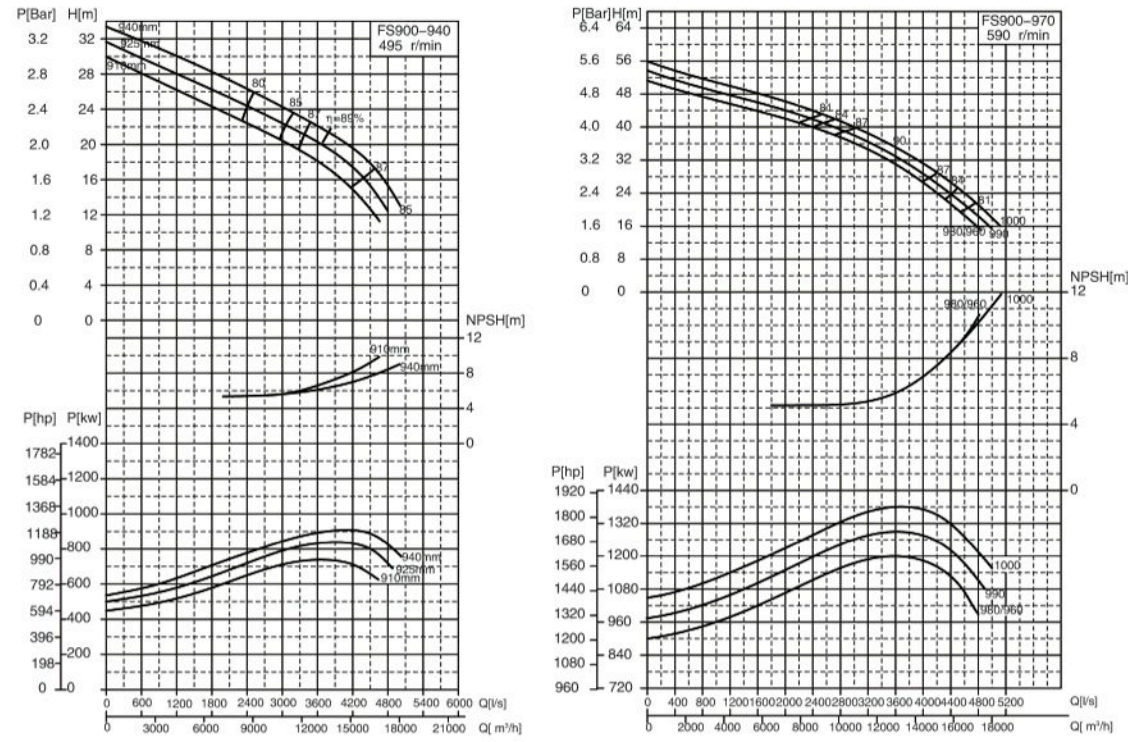

DOUBLE SUCTION CENTRIFUGAL PUMP

FS SERIES / 单级双吸离心泵
FS系列

VII、PERFORMANCE CURVE CHART 性能曲线图

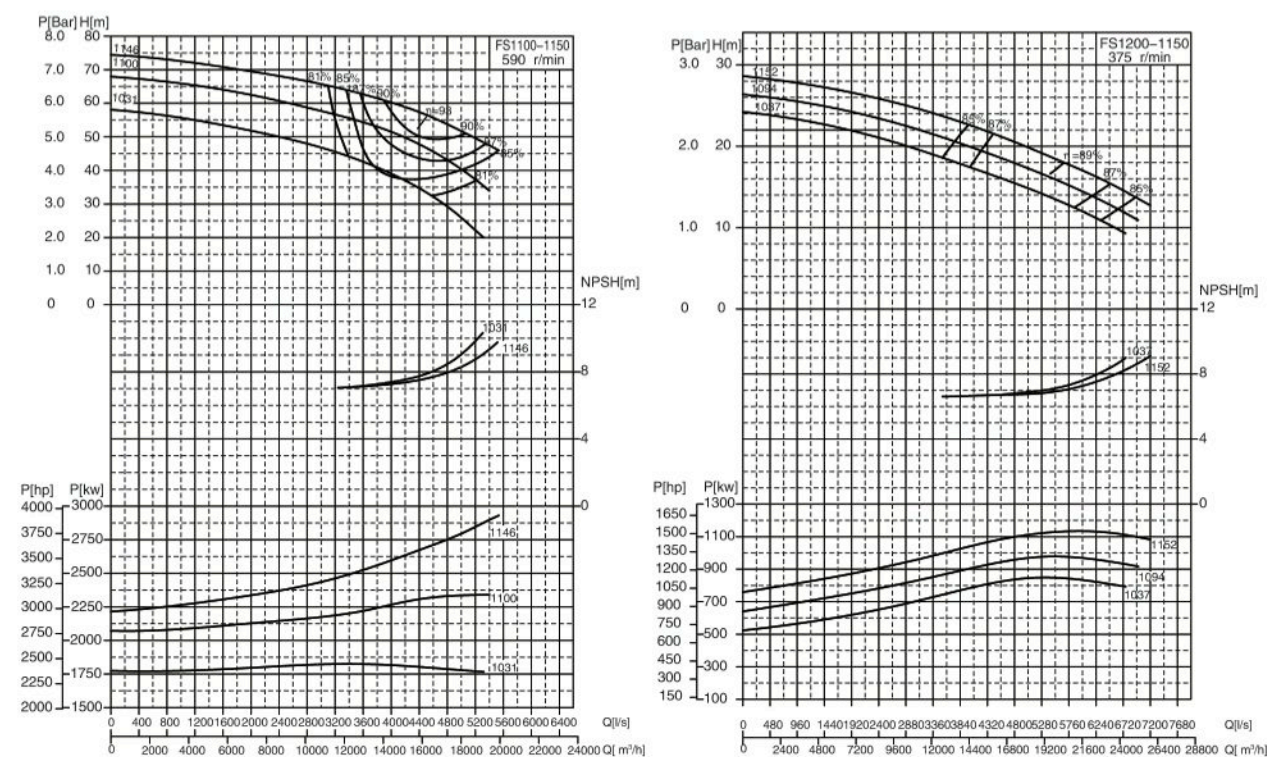
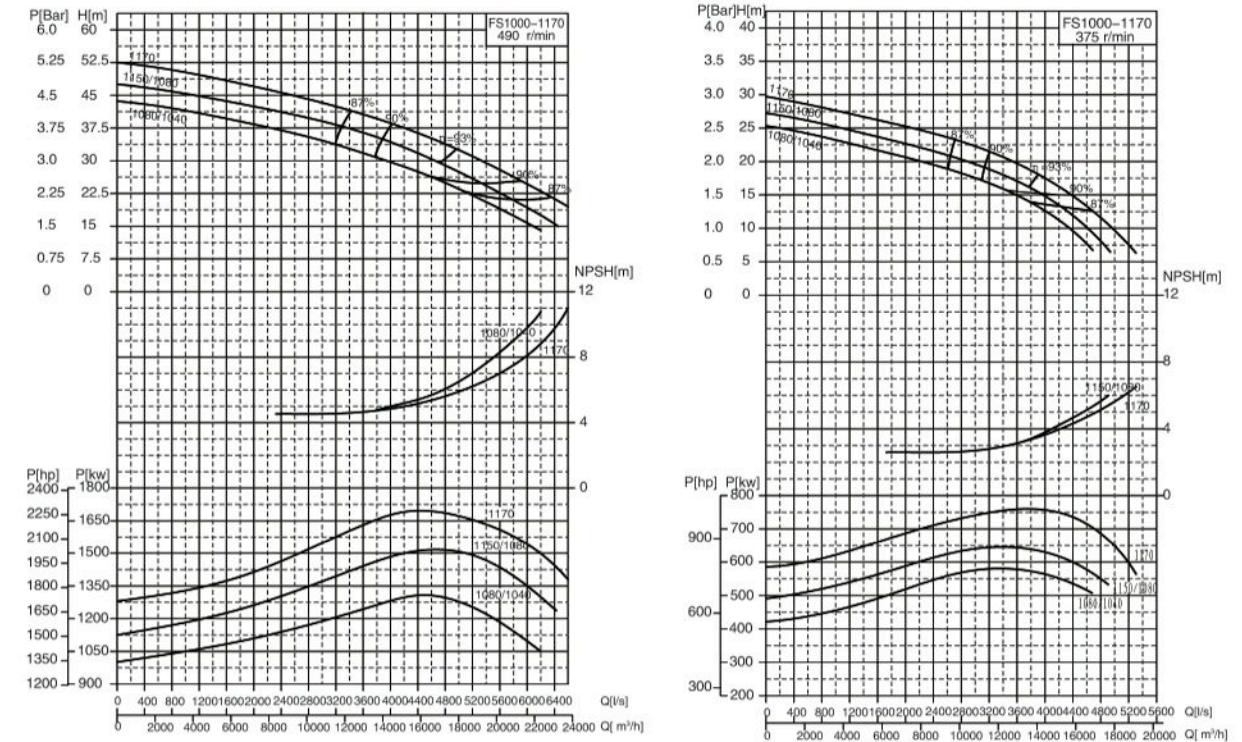

- FS
- FS80
- FS100
- FS125
- FS150
- FS200
- FS250
- FS300
- FS350
- FS400
- FS450
- FS500
- FS600
- FS700
- FS800
- FS900
- FS1000
- FS1100
- FS1200

DOUBLE SUCTION CENTRIFUGAL PUMP

FS SERIES / 单级双吸离心泵
FS系列

VII、PERFORMANCE CURVE CHART 性能曲线图

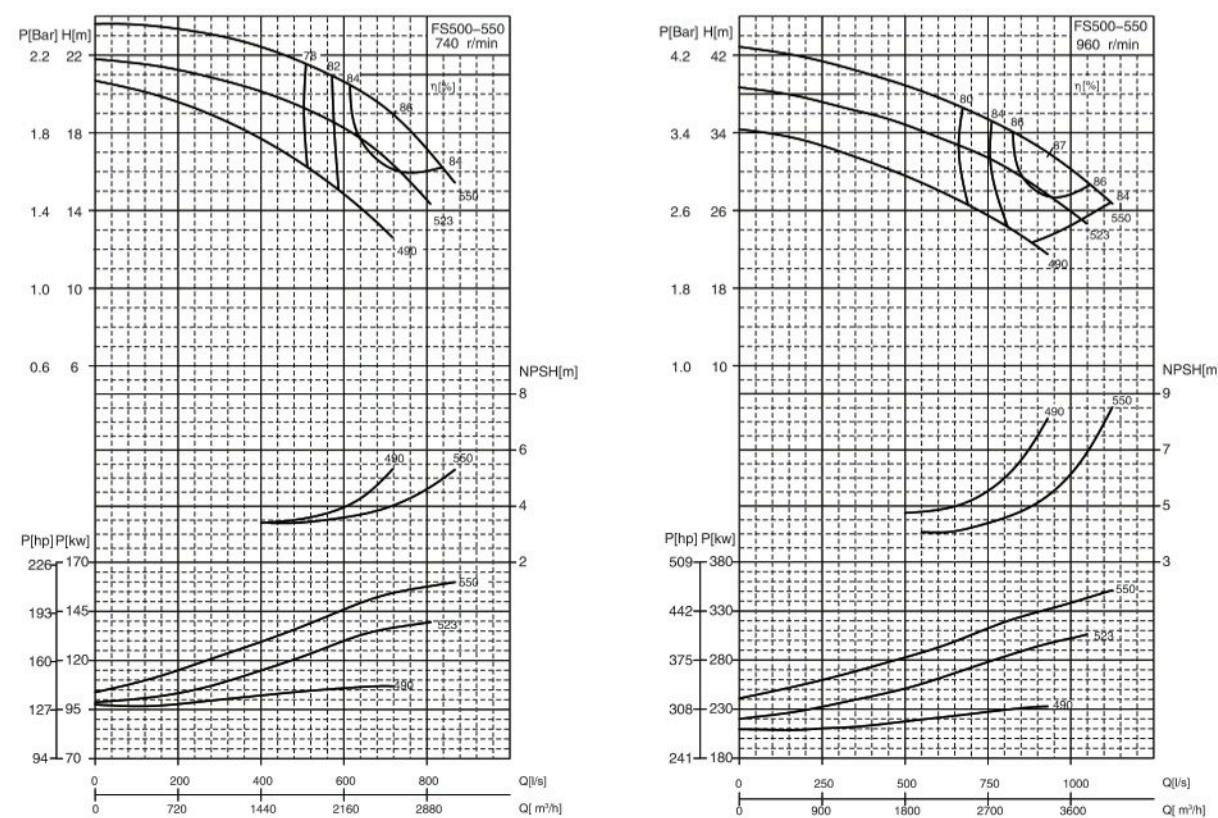
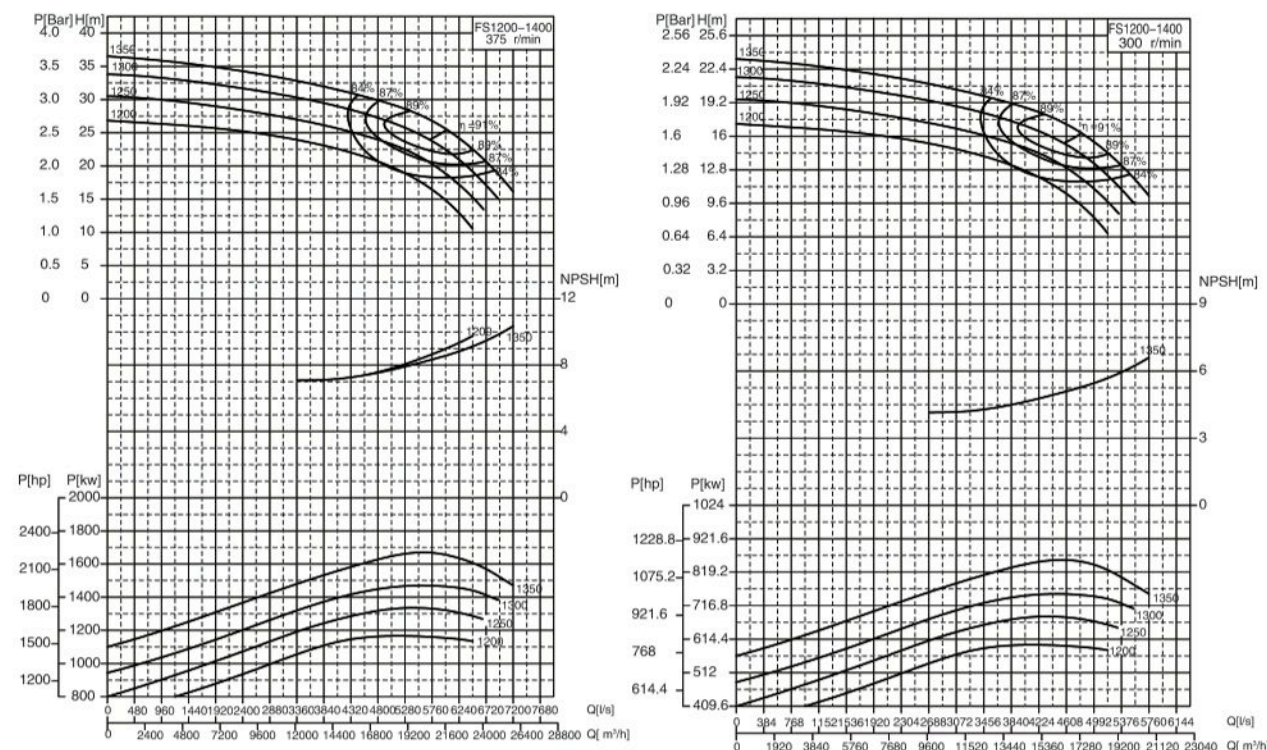

DOUBLE SUCTION CENTRIFUGAL PUMP

FS SERIES / 单级双吸离心泵
FS系列

VII、PERFORMANCE CURVE CHART 性能曲线图

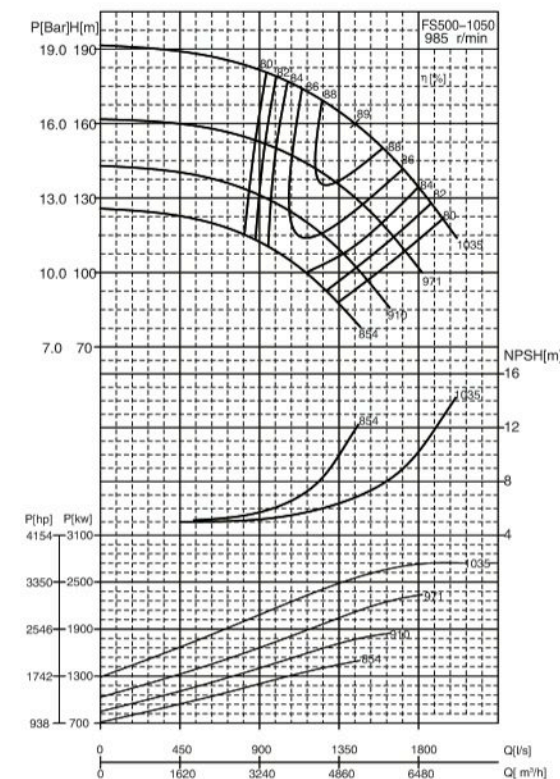

- FS
- FS80
- FS100
- FS125
- FS150
- FS200
- FS250
- FS300
- FS350
- FS400
- FS450
- FS500
- FS600
- FS700
- FS800
- FS900
- FS1000
- FS1100
- FS1200

DOUBLE SUCTION CENTRIFUGAL PUMP

FS SERIES / 单级双吸离心泵
FS系列

VIII、PERFORMANCE DATA 性能参数

(Type) 泵型号	(Capacity) 流量		Head扬程 (m)	Speed转速 (r/min)	Motor power 电机功率 (Kw)	Eff效率 (%)	叶轮直径 (mm)	汽蚀余量 (NPSH) (m)	
	(m³/h)	(L/s)							
FS80-210	A	50.1	13.9	16.0	1450	5.5	75.0	1.5	
		83.5	23.2	13.8			82.0	1.6	
		100.1	27.8	12.4			80.0	1.8	
		46.1	12.8	13.8			74.0	1.5	
		77.0	21.4	11.8			81.0	1.6	
		92.5	25.7	10.5			79.0	1.8	
	B	42.0	12.5	11.8	3	72.0	1.5		
		70.4	19.6	9.8		80.5	1.6		
		84.0	23.3	9.0		78.0	1.7		
		38.6	10.7	10.0		72.0	1.5		
		64.4	17.9	8.6		78.0	1.6		
		77.3	21.5	7.0		76.0	1.7		
	C	98.7	27.4	64.8	3	75.0	3.5		
		164.5	45.7	55.0		82.0	4.5		
		197.4	54.8	49.0		80.5	5.6		
		97.7	25.5	56.0		74.0	3.5		
		152.9	42.5	47.5		80.0	4.1		
		183.5	51.0	42.0		79.0	5.0		
	FS80-270	A	83.0	23.0	47.5	2900	30	73.0	3.5
			138.6	38.5	40.0			80.5	4.0
			166.2	46.1	36.0			78.0	4.5
			77.4	21.4	40.0			72.0	3.5
		B	128.4	37.5	33.5	30	77.8	3.8	
			154.0	42.8	30.0		76.0	4.0	
61.2			17.0	25.8	73.0		1.5		
102.6			28.5	22.5	78.5		2.5		
C		121.0	33.6	20.0	22	76.0	4.5		
		57.6	16.0	22.4		72.0	1.6		
		96.1	26.7	19.3		77.0	2.3		
		115.2	32.0	17.4		74.0	3.5		
FS80-370	A	52.9	14.7	18.0	1450	11	70.0	1.5	
		90.0	25.0	16.0			76.0	2.0	
		105.8	29.4	14.3			74.0	3.0	
		47.6	13.2	15.7			68.0	1.5	
	B	79.4	22.0	13.0	7.5	75.0	2.0		
		95.3	26.5	11.6		73.0	2.1		
		126.0	35.0	103.0		73.0	2.5		
		207.0	57.5	90.0		78.5	6.3		
	C	234.0	65.0	84.0	5.5	78.0	12.5		
		115.2	32.0	90.0		72.0	2.5		
		192.3	53.4	77.0		77.5	5.2		
		234.0	65.0	68.0		75.0	13.0		
FS80-210	A	107.3	29.8	75.0	2900	75	72.0	2.5	
		174.6	48.5	65.0			76.0	4.0	
		209.5	58.2	57.5			74.0	7.5	
		93.0	25.8	63.0			71.0	2.5	
	B	172.8	48.0	50.0	55	75.0	4.0		
		216.0	60.0	41.0		74.0	10.2		
		67.0	18.6	42.5		66.0	1.8		
		111.6	31.0	38.0		75.0	2.0		
	C	133.2	37.0	34.0	37	72.0	4.0		
		63.4	17.6	36.5		66.0	1.8		
		104.4	29.0	33.0		72.0	1.9		
		126.7	35.2	27.0		69.0	3.1		
FS100-250	A	57.6	16.0	30.0	1450	15	66.0	1.8	
		96.5	26.8	26.5			70.0	1.9	
		115.6	32.7	22.0			66.0	3.0	
		52.2	14.5	25.0			63.0	1.8	
	B	87.1	24.2	21.5	15	67.0	1.9		
		104.4	29.0	18.0		62.0	2.0		
		90.7	25.2	22.0		77.0	2.3		
		151.2	42.0	18.5		83.0	2.4		
	C	198.0	55.0	14.5	11	78.0	3.2		
		79.2	22.0	18.7		73.0	2.3		
		133.2	37.0	15.8		81.0	2.4		
		162.0	45.0	14.0		80.0	2.8		
FS100-310	A	73.7	20.5	16.0	1450	11	72.0	2.3	
		122.4	34.0	13.5			79.0	2.4	
		147.5	41.0	12.0			78.0	2.6	
		69.5	19.3	13.5			72.0	2.3	
	B	118.8	33.0	11.0	7.5	77.5	2.4		
		139.0	38.6	10.0		76.0	2.6		
		90.7	25.2	22.0		77.0	2.3		
		151.2	42.0	18.5		83.0	2.4		
	FS100-375	A	198.0	55.0	14.5	2900	11	78.0	3.2
			79.2	22.0	18.7			73.0	2.3
			133.2	37.0	15.8			81.0	2.4
			162.0	45.0	14.0			80.0	2.8
B		73.7	20.5	16.0	7.5	72.0	2.3		
		122.4	34.0	13.5		79.0	2.4		
		147.5	41.0	12.0		78.0	2.6		
		69.5	19.3	13.5		72.0	2.3		
C		118.8	33.0	11.0	7.5	77.5	2.4		
		139.0	38.6	10.0		76.0	2.6		
		90.7	25.2	22.0		77.0	2.3		
		151.2	42.0	18.5		83.0	2.4		

DOUBLE SUCTION CENTRIFUGAL PUMP

FS SERIES / 单级双吸离心泵
FS系列

(Type) 泵型号	(Capacity) 流量		Head扬程 (m)	Speed转速 (r/min)	Motor power 电机功率 (Kw)	Eff效率 (%)	叶轮直径 (mm)	汽蚀余量 (NPSH) (m)
	(m³/h)	(L/s)						
FS100-250	A	205.2	57.0	85.0	2900	90	78.0	5.8
		295.2	82.0	74.0			83.0	7.3
		378.0	105.0	62.0			79.0	11.0
		180.0	50.0	74.0			76.0	5.8
		277.2	77.0	63.0			81.5	7.5
		360.0	100.0	49.0			78.0	11.2
	B	198.0	55.0	60.0	55	76.0	6.2	
		252.0	70.0	53.0		79.0	7.6	
		324.0	90.0	44.0		76.0	11.5	
		201.6	56.0	48.0		76.0	6.7	
		241.2	67.0	43.0		78.0	8.2	
		306.0	85.0	35.0		74.0	11.0	
FS100-310	A	105.8	29.4	36.3	1450	22	73.0	1.5
		176.4	49.0	31.2			80.0	2.6
		216.0	60.0	26.8			77.0	4.3
		108.0	30.0	30.4			74.0	1.5
		158.4	44.0	27.0			79.0	2.1
		207.0	57.5	22.5			76.0	2.8
	B	97.2	27.0	26.0	15	74.0	1.5	
		144.0	40.0	22.5		79.0	1.9	
		180.0	50.0	19.5		76.0	3.0	
		82.8	23.0	22.0		74.0	1.5	
		133.2	37.0	18.5		79.0	1.7	
		162.0	45.0	16.1		76.0	2.8	
FS100-375	A	234.0	65.0	145.0	2900	185	76.0	5.2
		349.2	97.0	126.0			80.0	9.6
		388.8	108.0	118.0			79.0	12.0
		216.0	60.0	123.0			74.0	4.2
		324.0	90.0	108.0			79.0	9.4
		396.0	110.0	92.0			76.0	12.5
	B	205.2	57.0	103.0	132	75.0	4.2	
		288.0	80.0	92.0		75.0	4.2	
		360.0	100.0	78.0		79.0	6.5	
		154.8	43.0	88.0		76.0	12.5	
		266.4	74.0	77.0		74.0	4.2	
		324.0	90.0	66.0		75.0	6.2	
FS100-230	A	113.4	31.5	61.0	1450	90	68.0	11.0
		189.0	52.5	51.0			76.5	2.3
		216.0	60.0	45.0			74.0	4.1
		126.0	35.0	49.0			70.0	2.3
		169.2	47.0	44.0			74.0	2.3
		198.0	55.0	38.0			72.0	3.5
	B	91.8	25.5	44.0	30	63.0	2.3	
		153.0	42.5	38.0		72.0	2.4	
		183.6	51.0	33.0		69.0	3.5	
		93.6	26.0	33.5		63.0	2.3	
		133.2	37.0	29.0		68.0	2.3	
		170.0	47.2	24.0		64.0	3.2	
FS125-230	A	154.8	43.0	19.0	1450	18.5	74.0	1.6
		262.8	73.0	15.0			85.5	1.8
		329.4	91.5	12.0			82.0	2.4
		155.6	43.2	16.2			73.0	1.6
		241.2	67.0	13.0			84.0	1.8
		328.9	91.5	9.0			76.0	2.4
	B	144.0	40.0	14.0	15	73.0	1.6	
		225.0	62.5	11.0		82.0	1.8	
		279.0	77.5	8.0		75.0	2.3	
		118.8	33.0	12.0		70.0	1.8	
		198.0	55.0	9.0		77.0	1.8	
		241.2	67.0	7.0		74.0	2.1	
FS100-250	A	324.0	90.0	75.0	2900	110	75.0	6.0
		540.0	150.0	60.0			85.5	7.5
		637.2	177.0	50.0			83.0	9.2
		324.0	90.0	64.0			75.0	6.0
		496.8	138.0	52.0			84.0	6.8
		596.2	165.6	42.0			80.0	8.4
	B	288.0	80.0	55.0	90	73.0	6.8	
		450.0	125.0	43.5		80.0	8.4	
		579.6	161.0	30.0		73.0	6.8	
		252.0	70.0	47.0		82.0	7.0	
		414.0	115.0	35.0		75.0	9.2	
		475.2	132.0	28.0		76.0	7.3	
FS100-310	A	205.2	57.0	85.0	1450	15	78.0	5.8
		295.2	82.0	74.0			83.0	7.3
		378.0	105.0	62.0			79.0	11.0
		180.0	50.0	74.0			76.0	5.8
		277.2	77.0	63.0			81.5	7.5
		360.0	100.0	49.0			78.0	11.2
	B	198.0	55.0	60.0	11	76.0	6.2	
		252.0	70.0	53.0		79.0	7.6	
		324.0	90.0	44.0		76.0	11.5	
		201.6	56.0	48.0		76.0	6.7	
		241.2	67.0	43.0		78.0	8.2	
		306.0	85.0	35.0		74.0	11.0	

FS

DATA

DOUBLE SUCTION CENTRIFUGAL PUMP

FS SERIES / 单级双吸离心泵
FS系列

VIII、PERFORMANCE DATA 性能参数

(Type) 泵型号	(Capacity) 流量		Head扬程 (m)	Speed转速 (r/min)	Motor power 电机功率 (Kw)	Eff效率 (%)	叶轮直径 (mm)	汽蚀余量 (NPSH) (m)		
	(m³/h)	(L/s)								
FS125-290	A	144.0	40.0	32.0	30	74.0	301	1.6		
		270.0	75.0	26.8		84.0		1.9		
		360.0	100.0	21.0		79.0		3.6		
		144.0	40.0	26.5		74.0		1.6		
		241.2	67.0	22.0		82.0		1.7		
		324.0	90.0	17.5		78.0		2.8		
	B	144.0	40.0	21.8	18.5	74.0	254	1.6		
		226.8	63.0	18.0		80.0		1.8		
		306.0	85.0	13.0		74.0		2.8		
		144.0	40.0	17.0		70.0		1.7		
		207.0	57.5	14.0		78.0		1.8		
		266.4	74.0	10.5		74.0		2.6		
	C	396.0	110.0	12.0	15	80.0	232	6.4		
		540.0	150.0	10.8		84.0		7.6		
		648.0	180.0	9.4		81.0		10.8		
		288.0	80.0	105.0		220		75.0	301	6.4
		468.0	130.0	90.0				82.0		7.1
		558.0	155.0	80.0				81.0		8.8
	252.0	70.0	90.0	160	73.0		276	6.5		
	435.6	121.0	77.0		70.0			7.0		
	540.0	150.0	62.0		80.0			8.8		
	252.0	70.0	71.0		132	78.0		254	7.0	
	414.0	115.0	57.0			78.0			6.9	
	540.0	150.0	40.0			72.0			7.1	
180.0	50.0	52.0	90	75.0		232	9.1			
313.2	87.0	46.0		76.0			2.0			
432.0	120.0	38.0		84.0			2.1			
169.2	47.0	43.5		74.0	8.2					
288.0	80.0	39.0		74.0	2.1					
367.2	102.0	34.0		83.0	2.4					
FS125-360	A	162.0	45.0	35.0	45	78.0	353	3.0		
		259.2	72.0	30.5		74.0		2.1		
		324.0	90.0	27.3		80.0		2.2		
	B	180.0	50.0	26.0		37		74.0	321	4.0
		234.0	65.0	24.0				76.0		2.3
		280.8	78.0	20.2				74.0		2.5
C	280.8	78.0	20.2	30	74.0		289	3.0		
	180.0	50.0	84.5		74.0			1.6		
	324.0	90.0	77.0		82.0			2.5		
FS125-500	A	396.0	110.0		70.0	110		78.0	475	4.0
		180.0	50.0		73.0			74.0		1.6
		280.8	78.0		67.0			80.0		2.1
	B	324.0	90.0	63.0	90		78.0	443		3.2
		180.0	50.0	61.5			74.0			1.6
		244.8	68.0	57.0			78.0			1.8
C	309.6	86.0	52.0	75		74.0	412		3.2	
	187.2	52.0	50.5			74.0			1.7	
	216.0	60.0	48.0			76.0			1.8	
FS150-290	A	266.4	74.0		42.0	45		72.0	381	2.6
		259.2	72.0		26.4			76.0		2.0
		435.6	121.0		21.0			86.0		2.5
	B	576.0	160.0	16.0	37		78.0	289		4.0
		252.0	70.0	23.0			75.0			2.5
		417.6	116.0	18.0			85.0			2.5
C	540.0	150.0	12.4	30		76.0	269		3.8	
	270.0	75.0	18.3			75.0			2.4	
	378.0	105.0	15.0			82.0			2.5	
FS150-360	A	486.0	135.0		11.0	22		76.0	248	3.4
		270.0	75.0		14.0			75.0		2.5
		338.4	94.0		11.7			77.0		2.6
	B	432.0	120.0	8.0	18.5		72.0	227		3.0
		252.0	70.0	44.0			76.0			2.1
		450.0	125.0	38.0			85.0			2.5
C	576.0	160.0	30.0	75		80.0	355		4.4	
	252.0	70.0	37.0			76.0			2.3	
	396.0	110.0	31.0			83.0			2.4	
FS150-605	A	540.0	150.0		24.0	55		76.0	325	4.1
		252.0	70.0		30.5			76.0		2.4
		378.0	105.0		25.0			80.0		2.6
	B	486.0	135.0	18.0	37		76.0	299		3.4
		252.0	70.0	24.0			76.0			2.5
		338.4	94.0	20.0			78.0			2.6
C	432.0	120.0	14.0	30		76.0	274		3.0	
	252.0	70.0	20.0			76.0			2.5	
	338.4	94.0	20.0			78.0			2.6	

DOUBLE SUCTION CENTRIFUGAL PUMP

FS SERIES / 单级双吸离心泵
FS系列

(Type) 泵型号	(Capacity) 流量		Head扬程 (m)	Speed转速 (r/min)	Motor power 电机功率 (Kw)	Eff效率 (%)	叶轮直径 (mm)	汽蚀余量 (NPSH) (m)			
	(m³/h)	(L/s)									
FS150-450	A	288.0	80.0	74.0	1450	132	72.0	454	2.5		
		514.8	143.0	66.0			82.0		3.5		
		612.0	170.0	60.0			79.0		5.4		
		270.0	75.0	62.5			72.0		2.5		
		468.0	130.0	55.0			81.0		3.5		
		594.0	165.0	45.0			75.0		6.5		
	B	259.2	72.0	51.0		110	72.0	416	2.7		
		417.6	116.0	45.0			80.0		3.0		
		540.0	150.0	34.0			72.0		8.0		
		252.0	70.0	41.0			75		72.0	378	2.7
		374.4	104.0	35.0					78.0		3.6
		468.0	130.0	28.0					72.0		5.0
C	306.0	85.0	117.0	55	70.0	340		3.0			
	583.0	162.0	105.0		81.0			3.8			
	720.0	200.0	96.0		78.0			7.0			
	306.0	85.0	102.0		70.0		3.0				
	540.0	150.0	90.0		80.0		3.7				
	648.0	180.0	80.0		76.0		6.0				
FS150-605	A	295.2	82.0	87.0	1450	250	70.0	560	3.0		
		493.6	135.0	77.0			81.0		3.8		
		576.0	160.0	70.0			78.0		7.0		
		288.0	80.0	70.0			70.0		3.0		
		432.0	120.0	64.0			80.0		3.7		
		540.0	150.0	55.0			76.0		6.0		
	B	432.0	120.0	37.0		200	70.0	523	3.0		
		705.6	196.0	30.0			80.0		3.7		
		936.0	260.0	20.0			76.0		6.0		
		432.0	120.0	32.0			70.0		3.0		
		648.0	180.0	25.5			80.0		3.0		
		864.0	240.0	17.0			78.0		3.4		
C	432.0	120.0	26.0	160	70.0	486	4.2				
	594.0	165.0	21.3		70.0		3.0				
	720.0	200.0	17.0		78.0		3.4				
	360.0	100.0	23.0		76.0		4.2				
	540.0	150.0	17.5		70.0		3.0				
	720.0	200.0	10.0		70.0		3.1				
FS200-320	A	432.0	120.0	60.0	1450	75	78.0	338	3.1		
		712.8	198.0	52.0			87.0		3.5		
		961.2	267.0	40.0			78.0		5.8		
		432.0	120.0	32.0			80.0		3.1		
		648.0	180.0	25.5			77.0		3.6		
		864.0	240.0	17.0			77.0		5.6		
	B	432.0	120.0	26.0		75	77.0	314	3.2		
		594.0	165.0	21.3			84.0		3.3		
		720.0	200.0	17.0			80.0		4.2		
		360.0	100.0	23.0			72.0		3.5		
		540.0	150.0	17.5			78.0		3.6		
		720.0	200.0	10.0			78.0		4.5		
FS200-420	A	432.0	120.0	60.0	1450	37	78.0	266	3.2		
		712.8	198.0	52.0			80.0		4.5		
		961.2	267.0	40.0			78.0		3.2		
		432.0	120.0	32.0			86.0		3.6		
		648.0	180.0	25.5			77.0		5.6		
		864.0	240.0	17.0			77.0		3.2		
	B	432.0	120.0	26.0		55	77.0	290	3.2		
		594.0	165.0	21.3			84.0		3.3		
		720.0	200.0	17.0			80.0		4.2		
		360.0	100.0	23.0			72.0		3.5		
		540.0	150.0	17.5			78.0		3.6		
		720.0	200.0	10.0			78.0		4.5		
FS200-520	A	432.0	120.0	60.0	1450	132	78.0	415	3.2		
		712.8	198.0	52.0			86.0		3.8		
		961.2	267.0	40.0			80.0		7.0		
		432.0	120.0	32.0			78.0		3.5		
		648.0	180.0	25.5			84.0		3.8		
		864.0	240.0	17.0			79.0		6.0		
	B	432.0	120.0	26.0		110	76.0	380	3.7		
		594.0	165.0	35.0			76.0		3.7		
		720.0	200.0	17.0			76.0		4.8		
		360.0	100.0	34.0			77.0		3.9		
		540.0	150.0	17.5			80.0		4.3		
		720.0	200.0	10.0			78.0		4.3		
FS200-670	A	489.6	136.0	103.0	1450	75	76.0	320	2.5		
		820.8	228.0	91.0			84.0		3.5		
		1008.0	280.0	81.0			81.0		6.1		
		489.6	136.0	103.0			76.0		2.5		
		792.0	220.0	75.0			83.0		4.0		
		900.0	250.0	70.0			81.0		6.2		
	B	468.0	130.0	70.0		250	74.0	486	2.5		
		720.0	200.0	62.0			81.0		3.6		
		828.0	230.0	57.0			80.0		5.6		
		432.0	120.0	55.0			73.0		2.5		
		648.0	180.0	47.5			79.0		3.4		
		756.0	210.0	42.5			77.0		6.5		
FS200-770	A	432.0	120.0	163.0	1450	185	70.0	442	2.5		
		792.0	220.0	150.0			81.0		3.1		
		864.0	240.0	145.0			80.0		4.6		
		432.0	120.0	140.0			70.0		2.6		
		421.2	117.0	140.0			70.0		2.6		
		702.0	195.0	128.0			80.0		2.8		
	B	828.0	230.0	120.0		132	77.0	398	4.0		
		403.2	112.0	120.0			70.0		2.7		
		669.6	186.0	107.0			77.0		2.7		
		792.0	220.0	100.0			75.0		3.2		
		396.0	110.0	100.0			69.0		2.6		
		630.0	175.0	90.0			75.0		2.6		
FS200-930	A	764.9	210.0	80.0	1450	355	74.0	611	3.2		
		403.2	112.0	120.0			70.0		2.7		
		669.6	186.0	107.0			77.0		2.7		
		792.0	220.0	100.0			75.0		3.2		
		396.0	110.0	100.0			69.0		2.6		
		630.0	175.0	90.0			75.0		2.6		

FS

DATA

DOUBLE SUCTION CENTRIFUGAL PUMP

FS SERIES / 单级双吸离心泵
FS系列

VIII、PERFORMANCE DATA 性能参数

(Type) 泵型号		(Capacity) 流量		Head扬程 (m)	Speed转速 (r/min)	Motor power 电机功率 (Kw)	Eff效率 (%)	叶轮直径 (mm)	汽蚀余量 (NPSH) (m)
		(m³/h)	(L/s)						
FS250-370	A	720.0	200.0	46.0	1450	160	80.0	389	4.1
		1062.0	295.0	39.0			88.0		4.3
		1368.0	380.0	30.5			80.0		6.0
		648.0	180.0	41.0			76.0		4.2
		1008.0	280.0	33.5			86.0		4.7
		1296.0	360.0	24.5			76.0		6.2
	B	648.0	180.0	34.0		132	75.0	362	4.3
		936.0	260.0	27.0			83.0		4.6
		1152.0	320.0	20.5			76.0		5.7
		576.0	160.0	27.5			74.0		4.5
		864.0	240.0	20.0			77.5		4.7
		1008.0	280.0	16.0			74.0		5.2
FS250-480	A	720.0	200.0	77.0	1450	280	80.0	478	3.8
		1206.0	335.0	65.0			88.0		4.0
		1584.0	440.0	52.0			82.0		7.6
		666.0	185.0	65.0			77.0		3.8
		1080.0	300.0	55.0			86.0		4.0
		1440.0	400.0	42.0			80.0		5.6
	B	576.0	160.0	55.0		220	75.0	438	3.9
		1008.0	280.0	45.0			84.0		3.9
		1296.0	360.0	35.0			76.0		4.7
		576.0	160.0	46.0			74.0		4.0
		936.0	260.0	37.0			81.0		4.0
		1152.0	320.0	30.0			75.0		4.5
FS250-600	A	828.0	230.0	130.0	1450	560	80.0	610	2.8
		1224.0	340.0	117.0			84.0		3.8
		1656.0	460.0	96.0			80.0		8.2
		720.0	200.0	113.0			76.0		2.8
		1152.0	320.0	100.0			83.5		3.8
		1512.0	420.0	80.0			77.0		9.5
	B	648.0	180.0	97.0		315	74.0	520	2.8
		1080.0	300.0	83.0			83.0		3.5
		1260.0	350.0	75.0			82.0		5.3
		648.0	180.0	80.0			76.0		2.8
		1008.0	280.0	67.0			82.0		3.4
		1224.0	340.0	58.0			80.0		5.3
FS250-800	A	884.0	240.0	228.0	1480	1120	77.0	770	4.3
		1296.0	360.0	216.0			83.0		4.5
		1440.0	400.0	205.0			82.0		5.0
		720.0	200.0	31.0			74.0		4.2
		1126.8	313.0	24.0			86.5		4.6
		1352.0	380.0	19.0			82.0		6.8
	B	684.0	190.0	26.0		75	74.0	308	4.5
		1044.0	290.0	20.0			84.0		4.8
		1296.0	360.0	14.5			78.0		6.0
		720.0	200.0	20.5			74.0		4.8
		972.0	270.0	16.0			82.0		5.1
		1152.0	320.0	11.0			78.0		5.8
FS300-300	A	648.0	180.0	17.0	1450	45	73.0	274/259	5.0
		936.0	260.0	12.0			79.0		5.2
		1152.0	320.0	8.0			74.0		5.8
		1080.0	300.0	64.0			78.0		4.5
		1710.0	475.0	52.5			89.0		5.2
		2070.0	575.0	45.0			86.0		6.5
	B	1080.0	300.0	55.0		315	78.0	450	4.7
		1620.0	450.0	45.0			86.5		5.3
		2160.0	600.0	30.0			76.0		8.5
		1080.0	300.0	44.0			78.0		4.9
		1476.0	410.0	37.0			83.0		4.9
		1836.0	510.0	28.0			78.0		7.3
FS300-435	A	1080.0	300.0	38.0	1450	280	76.0	418	5.2
		1350.0	375.0	27.5			78.5		6.6
		1620.0	450.0	25.0			78.0		7.2
		1080.0	300.0	107.0			80.0		3.9
		1692.0	470.0	95.0			87.0		4.7
		2340.0	650.0	77.0			80.0		7.4
	B	900.0	250.0	90.0		200	75.0	386	4.3
		1620.0	450.0	77.0			85.0		5.2
		2160.0	600.0	61.5			81.0		7.8
		900.0	250.0	74.0			75.0		4.6
		1548.0	430.0	62.0			85.0		5.3
		1888.4	524.0	53.0			82.0		7.1

DOUBLE SUCTION CENTRIFUGAL PUMP

FS SERIES / 单级双吸离心泵
FS系列

(Type) 泵型号		(Capacity) 流量		Head扬程 (m)	Speed转速 (r/min)	Motor power 电机功率 (Kw)	Eff效率 (%)	叶轮直径 (mm)	汽蚀余量 (NPSH) (m)
		(m³/h)	(L/s)						
FS300-560	C	972.0	270.0	60.0	1450	280	75.0	426	5.0
		1512.0	420.0	50.0			83.5		5.7
		1980.0	550.0	37.0			75.0		9.3
FS300-700	A	900.0	250.0	182.0	1450	1120	75.0	705	3.9
		1836.0	510.0	160.0			86.0		4.5
		2052.0	570.0	152.0			85.0		4.8
		936.0	260.0	160.0			75.0		4.0
		1728.0	480.0	136.0			84.0		4.3
		2268.0	630.0	114.0			80.0		10.0
	B	900.0	250.0	132.0		900	76.0	655	4.0
		1620.0	450.0	112.0			84.0		4.4
		1180.0	500.0	106.0			83.0		6.7
		900.0	250.0	108.0			75.0		4.0
		1512.0	420.0	91.0			83.0		4.3
		1872.0	520.0	80.0			80.0		8.2
FS350-360	A	1260.0	350.0	39.0	1450	200	78.0	382	6.0
		1728.0	480.0	32.0			86.0		6.7
		2160.0	600.0	24.0			80.0		8.6
		1080.0	300.0	36.0			73.0		6.3
		1692.0	470.0	27.0			84.0		7.1
		2160.0	600.0	17.0			74.0		9.4
	B	1080.0	300.0	29.0		132	82.0	332	7.0
		1620.0	450.0	21.5			82.0		7.0
		1980.0	550.0	15.0			76.0		8.1
		972.0	270.0	24.0			70.0		6.8
		1548.0	430.0	16.0			78.0		7.3
		1872.0	520.0	10.0			74.0		8.4
FS350-430	A	1620.0	450.0	54.0	1450	450	73.0	440	7.5
		2808.0	780.0	42.0			86.5		8.7
		3294.0	915.0	35.0			83.0		11.2
		1728.0	480.0	45.0			74.0		8.1
		2628.0	730.0	35.0			84.0		8.6
		3024.0	840.0	30.0			82.0		10.3
	B	1620.0	450.0	37.5		355	71.0	411	8.5
		2520.0	700.0	27.5			82.0		8.6
		3060.0	850.0	21.0			78.0		11.5
		1620.0	450.0	30.0			70.0		8.9
		2412.0	670.0	22.0			78.0		9.7
		2880.0	800.0	16.0			74.0		11.0
FS350-510	A	1800.0	500.0	83.0	1450	630	82.0	518	6.0
		2664.0	740.0	70.0			87.5		6.8
		3420.0	950.0	54.0			81.0		10.6
		1620.0	450.0	73.0			78.0		6.8
		2430.0	675.0	60.0			86.0		7.4
		3240.0	900.0	43.0			81.0		10.3
	B	1620.0	450.0	60.0		400	78.0	445	7.4
		2340.0	650.0	48.0			84.0		8.0
		2880.0	800.0	41.0			77.0		10.1
		1620.0	450.0	46.0			74.0		8.0
		2070.0	575.0	38.0			78.0		8.3
		2700.0	750.0	25.0			72.0		10.0
FS350-570	A	1800.0	500.0	117.0	1480	900	84.0	575	5.4
		2520.0	700.0	103.0			90.0		7.0
		3060.0	850.0	88.0			86.0		10.2
		1656.0	460.0	100.0			84.0		5.5
		2268.0	630.0	88.0			89.0		7.0
		2880.0	800.0	74.0			83.0		10.0
	B	1440.0	400.0	87.0		560	80.0	506	5.3
		2052.0	570.0	77.0			88.5		6.8
		2880.0	700.0	67.0			84.0		9.5
		1440.0	400.0	75.0			80.0		5.4
		1980.0	550.0	66.5			86.0		6.7
		2160.0	600.0	61.0			85.0		7.5
FS350-630	A	1296.0	360.0	140.0	1450	1000	74.0	640	4.7
		2160.0	600.0	126.0			85.0		6.9
		2592.0	720.0	116.0			82.0		9.5
		1296.0	360.0	128.0			76.0		4.8
		2016.0	560.0	116.0			84.0		6.5
		2520.0	700.0	100.0			81.0		9.3
	B	1188.0	330.0	118.0		900	76.0	610	4.6
		1908.0	530.0	106.0			83.5		5.8
		2304.0	640.0	96.0			82.5		7.6

FS

DATA

DOUBLE SUCTION CENTRIFUGAL PUMP

FS SERIES / 单级双吸离心泵
FS系列

VIII、PERFORMANCE DATA 性能参数

(Type) 泵型号		(Capacity) 流量		Head扬程 (m)	Speed转速 (r/min)	Motor power 电机功率 (Kw)	Eff效率 (%)	叶轮直径 (mm)	汽蚀余量 (NPSH) (m)			
		(m³/h)	(L/s)									
FS350-630	C	1116.0	310.0	107.0	1450	710	76.0	550	4.6			
		1800.0	500.0	96.0			83.5		5.6			
		2268.0	630.0	82.0			82.0		7.5			
	D	1044.0	290.0	93.8		560	76.0	510	4.5			
		1620.0	450.0	85.0			82.0		5.1			
		2160.0	600.0	69.0			78.0		7.0			
FS350-690	A	1800.0	500.0	174.0	1480	1400	85.0	690	5.5			
		2520.0	700.0	155.0			89.0		7.0			
		3060.0	850.0	136.0			85.5		10.2			
		B	1692.0	470.0		150.0	1200		84.0	647	5.5	
			2340.0	650.0		135.0			88.5		7.0	
			2736.0	760.0		120.0			85.0		9.5	
	C	1440.0	400.0	132.0	900	80.0	607	5.4				
		1980.0	550.0	120.0		87.5		6.6				
		2520.0	700.0	102.0		83.0		9.8				
		A	1440.0	400.0		113.0		710	80.0	569	5.5	
			2340.0	550.0		100.0			85.0		6.8	
			2160.0	600.0		90.0			83.0		7.8	
	FS400-525	A	2520.0	700.0	76.0	1480	800	82.0	525	6.8		
			3528.0	980.0	64.0			88.5		8.3		
			4320.0	1200.0	52.0			82.5		13.0		
			B	2340.0	650.0		64.0	630		80.0	492	6.8
				3240.0	900.0		55.0			87.5		8.2
				3960.0	1100.0		44.5			82.5		11.0
C		2160.0	600.0	46.0	500	77.0	462	6.7				
		2880.0	800.0	40.0		85.5		8.0				
		3240.0	900.0	35.0		80.0		12.0				
		A	2160.0	600.0		34.5		450	77.0	433	6.8	
			2880.0	800.0		40.0			82.0		8.0	
			3240.0	900.0		30.0			80.0		9.5	
FS400-665		A	2160.0	600.0	100.0	985	280	84.5	492	3.6		
			2808.0	780.0	30.0			89.5		4.4		
			3600.0	1000.0	22.5			82.5		7.2		
			B	1800.0	500.0		30.0	220		78.0	492	3.5
				2664.0	740.0		25.0			88.0		4.3
				3240.0	900.0		20.0			82.5		6.0
		C	1800.0	500.0	25.0	185	78.0	462	3.5			
			2520.0	700.0	21.0		85.5		4.4			
			3060.0	850.0	16.5		80.0		6.1			
			A	1800.0	500.0		21.0		160	78.0	433	3.6
				2340.0	650.0		18.0			82.0		4.1
				2772.0	770.0		15.0			80.0		5.3
	FS400-690	A	1584.0	440.0	98.0	1480	800	76.0	540	4.6		
			2628.0	730.0	86.0			85.0		7.0		
			3096.0	860.0	78.0			83.0		10.0		
			B	1512.0	420.0		91.0	710		75.0	520	4.6
				2520.0	700.0		79.0			84.0		6.5
				3024.0	840.0		69.0			81.0		9.5
C		1440.0	400.0	83.0	630	75.0	500	4.5				
		2412.0	670.0	72.0		84.0		6.3				
		2988.0	830.0	62.0		81.5		9.4				
		A	1386.0	385.0		76.0		630	75.0	480	4.5	
			2340.0	650.0		64.0			83.5		6.0	
			2880.0	800.0		52.0			80.0		8.4	
D		1368.0	380.0	69.0	560	75.0	460	4.5				
		2268.0	630.0	57.0		83.0		5.8				
		2808.0	780.0	49.0		78.0		7.3				
		A	1919.0	533.0		129.7		1250	76.0	620	4.4	
			3168.0	880.0		113.0			86.0		7.5	
			3888.0	1080.0		98.0			85.0		11.6	
FS400-600		B	1800.0	500.0	119.0	1450	1120	76.0	595	4.3		
			2988.0	830.0	103.0			85.5		6.8		
			3960.0	1100.0	82.0			82.0		12.0		
			C	1800.0	500.0		108.0	1000		79.0	570	4.3
				2880.0	800.0		93.0			85.0		6.5
				3780.0	1050.0		70.6			80.0		10.5
	D	1620.0	450.0	100.0	900	76.0	545	4.0				
		2700.0	750.0	84.0		85.0		6.0				
		3420.0	950.0	64.0		80.0		8.5				
		A	1530.0	425.0		90.0		800	76.0	520	4.0	
			2520.0	700.0		74.0			85.0		5.6	
			3060.0	850.0		60.0			80.0		7.0	

DOUBLE SUCTION CENTRIFUGAL PUMP

FS SERIES / 单级双吸离心泵
FS系列

(Type) 泵型号		(Capacity) 流量		Head扬程 (m)	Speed转速 (r/min)	Motor power 电机功率 (Kw)	Eff效率 (%)	叶轮直径 (mm)	汽蚀余量 (NPSH) (m)					
		(m³/h)	(L/s)											
FS400-665	A	2160.0	600.0	145.0	1480	1600	80.0	665	6.3					
		3600.0	1000.0	122.0			89.0		9.0					
		4320.0	1200.0	105.0			85.0		13.0					
		B	2160.0	600.0			123.0		250	80.0	642	6.3		
			3240.0	900.0			106.0			88.0		8.5		
			3960.0	1100.0			90.0			83.0		12.0		
	C	2160.0	600.0	104.0		185	80.0	585	6.4					
		2880.0	800.0	93.0			80.0		8.0					
		3600.0	1000.0	78.0			86.5		12.0					
		A	2160.0	600.0			88.0		132	80.5	549	6.5		
			2700.0	750.0			77.0			82.0		8.0		
			3240.0	900.0			69.0			80.0		10.5		
	B	1440.0	400.0	64.0		450	80.0	665	2.8					
		2340.0	650.0	55.0			89.0		3.9					
		2880.0	800.0	46.5			85.0		5.8					
		A	1440.0	400.0			54.0		355	80.0	624	2.8		
			2160.0	600.0			47.0			88.5		3.7		
			2700.0	750.0			39.0			82.0		5.7		
	C	1440.0	400.0	46.0		315	80.0	585	2.9					
		1980.0	550.0	40.3			86.0		3.7					
		2520.0	700.0	33.0			78.0		6.0					
		A	1440.0	400.0			39.0		250	80.0	549	3.0		
			1800.0	500.0			35.5			82.0		3.5		
			2160.0	600.0			30.5			80.0		4.8		
FS400-675	A	1440.0	400.0	79.0	985	560	80.0	705	2.8					
		2232.0	620.0	69.2			88.0		3.7					
		2970.0	825.0	55.0			80.0		7.0					
		B	1440.0	400.0			67.5		450	80.0	661	2.8		
			2052.0	570.0			60.0			87.0		3.8		
			2664.0	740.0			48.0			80.0		6.4		
	C	1368.0	380.0	58.0		400	80.0	620	2.8					
		1872.0	520.0	52.0			86.0		3.8					
		2376.0	660.0	42.8			80.0		5.6					
		A	1332.0	370.0			50.0		315	80.0	582	3.0		
			1728.0	480.0			45.0			82.0		3.5		
			2088.0	580.0			38.0			79.0		6.0		
	FS400-705	A	1440.0	400.0		78.0	985	560	80.0	705	2.8			
			2232.0	620.0		69.0			88.0		3.7			
			2736.0	760.0		60.0			83.5		5.5			
			B	1440.0		400.0			70.0		450	80.0	661	2.9
				2052.0		570.0			60.0			87.0		3.7
				2520.0		700.0			52.0			82.5		5.4
C		1080.0	300.0	60.0	355	72.0		620	2.7					
		1800.0	500.0	53.0		86.0			3.5					
		2340.0	650.0	43.0		80.5			5.5					
		A	1080.0	300.0		52.0			280	72.0	582	2.8		
			1800.0	500.0		43.5				82.0		3.7		
			2070.0	575.0		39.0				80.0		4.8		
FS400-900	A	1620.0	450.0	155.0	985	1600	75.0	935	3.0					
		2880.0	800.0	135.0			88.0		6.4					
		3348.0	930.0	123.0			86.0		11.0					
		B	1584.0	440.0			133.0		1250	75.0	877	3.0		
			2592.0	720.0			118.0			87.0		5.6		
			3060.0	850.0			108.0			84.0		10.0		
	C	1440.0	400.0	116.0		1000	75.0	822	3.0					
		2340.0	650.0	103.0			86.0		4.0					
		2700.0	750.0	95.0			82.0		7.0					
		A	1368.0	380.0			101.0		800	75.0	771	3.0		
			2160.0	600.0			90.0			84.0		3.6		
			2772.0	770.0			77.0			80.0		10.0		
	FS400-935	A	1800.0	500.0		153.0	985	1400	80.0	935	3.0			
			2880.0	800.0		135.0			88.0		6.5			
			3348.0	930.0		124.0			86.0		11.0			
			B	1800.0		500.0			131.0		1120	80.0	877	3.0
				2700.0		750.0			116.0			87.0		6.0
				2952.0		820.0			110.0			86.0		8.0
C		1620.0	450.0	114.0	900	80.0		822	3.0					
		2340.0	650.0	103.0		86.5			4.2					
		2520.0	700.0	99.0		86.0			5.0					
		A	1620.0	450.0		98.0			710	80.0	771	3.0		
			2160.0	600.0		90.0				82.0		3.7		
			2520.0	700.0		82.0				80.0		5.6		

FS

DATA

DOUBLE SUCTION CENTRIFUGAL PUMP

FS SERIES / 单级双吸离心泵
FS系列

VIII、PERFORMANCE DATA 性能参数

(Type) 泵型号	(Capacity) 流量		Head扬程 (m)	Speed转速 (r/min)	Motor power 电机功率 (Kw)	Eff效率 (%)	叶轮直径 (mm)	汽蚀余量 (NPSH) (m)
	(m³/h)	(L/s)						
FS500-520	A	2304.0	640.0	33.5	280	550/530	82.0	3.2
		3168.0	880.0	27.0			88.0	4.0
		4032.0	1120.0	20.0			83.0	6.7
		2304.0	640.0	30.4			82.0	3.4
		3096.0	860.0	24.0			87.0	4.5
		3960.0	1100.0	16.0			81.0	6.8
	B	2304.0	640.0	26.3	250	530/510	82.0	3.6
		3024.0	840.0	22.0			86.0	4.3
		3852.0	1070.0	14.5			80.0	6.8
		2160.0	600.0	25.0			80.0	3.7
		2952.0	820.0	19.6			85.0	4.3
		3744.0	1040.0	12.5			81.0	7.1
C	2160.0	600.0	22.0	220	510/490	80.0	3.9	
	2880.0	800.0	17.3			84.0	4.5	
	3180.0	1000.0	11.0			80.0	6.3	
	3132.0	870.0	44.0			85.0	4.5	
	4140.0	1150.0	37.5			90.0	5.6	
	4968.0	1380.0	30.0			85.0	8.0	
D	3096.0	860.0	36.0	200	490/470	85.0	5.0	
	3780.0	1050.0	32.0			89.0	5.5	
	4572.0	1270.0	26.0			84.0	7.3	
	2880.0	800.0	30.8			82.0	4.5	
	3600.0	1000.0	27.0			87.0	5.4	
	4320.0	1200.0	22.0			82.0	7.3	
FS500-585	A	2880.0	800.0	25.8	185	470/455	82.0	4.6
		3240.0	900.0	24.0			85.0	5.0
		3960.0	1100.0	19.0			80.0	6.5
		2520.0	700.0	53.7			80.0	3.9
		3600.0	1000.0	47.0			88.5	5.7
		4500.0	1290.0	35.0			80.0	9.6
	B	2412.0	670.0	51.0	500	640	80.0	9.6
		3420.0	950.0	45.0			80.0	3.8
		4392.0	1220.0	33.0			87.0	5.6
		2268.0	630.0	48.0			82.0	8.5
		3240.0	900.0	42.0			80.0	3.6
		3807.0	1190.0	30.0			86.0	5.0
C	2160.0	600.0	44.0	400	549	80.0	8.3	
	3015.0	850.0	37.0			80.0	3.5	
	3456.0	1080.0	28.0			85.0	4.8	
	2088.0	580.0	37.5			80.0	6.4	
	2700.0	750.0	34.0			80.0	3.4	
	3348.0	930.0	26.0			84.0	4.0	
FS500-650	A	2160.0	600.0	67.5	315	515	80.0	5.4
		4140.0	1150.0	58.0			82.0	7.3
		5040.0	1400.0	48.0			82.0	4.6
		2520.0	700.0	53.7			85.0	5.0
		3600.0	1000.0	47.0			80.0	6.5
		4500.0	1290.0	35.0			80.0	9.6
	B	2412.0	670.0	51.0	630	640	80.0	9.6
		3420.0	950.0	45.0			80.0	3.8
		4392.0	1220.0	33.0			87.0	5.6
		2268.0	630.0	48.0			82.0	8.5
		3240.0	900.0	42.0			80.0	3.6
		3807.0	1190.0	30.0			86.0	5.0
C	2160.0	600.0	44.0	560	625	80.0	8.3	
	3015.0	850.0	37.0			80.0	3.5	
	3456.0	1080.0	28.0			85.0	4.8	
	2088.0	580.0	37.5			80.0	6.4	
	2700.0	750.0	34.0			80.0	3.4	
	3348.0	930.0	26.0			84.0	4.0	
FS500-685	A	2160.0	600.0	67.5	280	483	80.0	5.4
		4140.0	1150.0	58.0			82.0	7.3
		5040.0	1400.0	48.0			82.0	4.6
		2520.0	700.0	53.7			85.0	5.0
		3600.0	1000.0	47.0			80.0	6.5
		4500.0	1290.0	35.0			80.0	9.6
	B	2412.0	670.0	51.0	630	640	80.0	9.6
		3420.0	950.0	45.0			80.0	3.8
		4392.0	1220.0	33.0			87.0	5.6
		2268.0	630.0	48.0			82.0	8.5
		3240.0	900.0	42.0			80.0	3.6
		3807.0	1190.0	30.0			86.0	5.0
C	2160.0	600.0	44.0	560	625	80.0	8.3	
	3015.0	850.0	37.0			80.0	3.5	
	3456.0	1080.0	28.0			85.0	4.8	
	2088.0	580.0	37.5			80.0	6.4	
	2700.0	750.0	34.0			80.0	3.4	
	3348.0	930.0	26.0			84.0	4.0	
FS500-710	A	2160.0	600.0	67.5	280	483	80.0	5.4
		4140.0	1150.0	58.0			82.0	7.3
		5040.0	1400.0	48.0			82.0	4.6
		2520.0	700.0	53.7			85.0	5.0
		3600.0	1000.0	47.0			80.0	6.5
		4500.0	1290.0	35.0			80.0	9.6
	B	2412.0	670.0	51.0	630	640	80.0	9.6
		3420.0	950.0	45.0			80.0	3.8
		4392.0	1220.0	33.0			87.0	5.6
		2268.0	630.0	48.0			82.0	8.5
		3240.0	900.0	42.0			80.0	3.6
		3807.0	1190.0	30.0			86.0	5.0
C	2160.0	600.0	44.0	560	625	80.0	8.3	
	3015.0	850.0	37.0			80.0	3.5	
	3456.0	1080.0	28.0			85.0	4.8	
	2088.0	580.0	37.5			80.0	6.4	
	2700.0	750.0	34.0			80.0	3.4	
	3348.0	930.0	26.0			84.0	4.0	

DOUBLE SUCTION CENTRIFUGAL PUMP

FS SERIES / 单级双吸离心泵
FS系列

(Type) 泵型号	(Capacity) 流量		Head扬程 (m)	Speed转速 (r/min)	Motor power 电机功率 (Kw)	Eff效率 (%)	叶轮直径 (mm)	汽蚀余量 (NPSH) (m)
	(m³/h)	(L/s)						
FS500-710	A	2520.0	700.0	89.0	1120	750	82.0	3.5
		3960.0	1100.0	78.0			90.0	4.6
		5040.0	1400.0	65.0			83.0	6.7
		2520.0	700.0	83.0			82.0	3.6
		3960.0	1100.0	73.0			89.0	5.2
		5040.0	1400.0	58.0			83.0	9.0
	B	2520.0	700.0	76.0	1000	720	83.0	3.8
		3600.0	1000.0	68.0			88.0	4.8
		4680.0	1300.0	56.0			82.0	7.8
		2340.0	650.0	67.0			81.0	3.5
		3240.0	900.0	60.0			84.0	4.8
		3960.0	1100.0	52.0			82.0	7.8
C	2340.0	650.0	67.0	900	690	81.0	3.5	
	3240.0	900.0	60.0			84.0	4.5	
	3960.0	1100.0	52.0			81.0	6.0	
	1800.0	500.0	58.0			72.0	3.6	
	2808.0	780.0	50.3			79.0	4.0	
	3600.0	1000.0	41.0			73.0	5.4	
FS500-800	A	2700.0	750.0	97.0	1250	790	81.0	3.6
		4500.0	1250.0	83.0			90.0	6.8
		5400.0	1500.0	73.0			88.0	10.0
		2700.0	750.0	85.0			81.0	3.7
		4050.0	1125.0	73.0			88.0	5.6
		5400.0	1500.0	53.0			80.0	11.4
	B	2700.0	750.0	79.0	1000	750	81.0	3.8
		3600.0	1000.0	66.0			86.0	5.4
		4500.0	1250.0	53.0			84.0	8.1
		2700.0	750.0	65.0			80.0	4.0
		3492.0	970.0	57.0			84.0	5.7
		4050.0	1125.0	51.0			82.0	7.1
C	2700.0	750.0	65.0	800	710	80.0	4.0	
	3600.0	1000.0	53.0			80.0	4.0	
	4500.0	1250.0	41.0			84.0	5.7	
	2700.0	750.0	57.0			82.0	7.1	
	3492.0	970.0	57.0			80.0	4.0	
	4050.0	1125.0	51.0			82.0	7.1	
FS500-835	A	2520.0	700.0	112.0	1400	835	83.0	4.1
		3744.0	1040.0	98.0			90.5	5.2
		4680.0	1300.0	83.0			85.0	8.0
		2160.0	600.0	97.5			80.0	4.2
		3420.0	950.0	85.0			89.5	5.2
		4104.0	1140.0	75.0			86.5	7.0
	B	1800.0	500.0	85.0	1120	783	74.0	4.0
		3168.0	880.0	73.0			88.0	5.0
		3960.0	1100.0	61.0			82.0	8.0
		2160.0	600.0	71.0			80.5	4.2
		2880.0	800.0	64.0			86.0	5.0
		3600.0	1000.0	53.0			80.0	7.5
C	3600.0	1000.0	132.0	900	689	86.0	4.3	
	5076.0	1410.0	116.0			90.0	6.1	
	6480.0	1800.0	97.0			87.0	10.8	
	3150.0	875.0	116.0			85.0	4.3	
	4500.0	1250.0	102.0			89.0	5.6	
	5400.0	1500.0	90.0			87.0	8.0	
FS500-860	A	2700.0	750.0	106.0	2000	930	83.0	4.5
		4050.0	1125.0	91.0			87.0	4.6
		4860.0	1350.0	80.0			85.0	6.8
		2700.0	750.0	90.0			83.0	4.6
		3600.0	1000.0	80.0			85.0	4.5
		4680.0	1300.0	62.0			78.0	7.9
	B	3600.0	1000.0	110.0	1600	870	85.0	5.1
		5184.0	1440.0	97.5			91.0	6.7
		6480.0	1800.0	81.0			85.0	10.3
		3240.0	900.0	95.0			85.0	5.1
		4680.0	1300.0	84.5			90.0	6.3
		5760.0	1600.0	72.0			85.0	9.0
C	3240.0	900.0	80.5	1800	807	82.0	5.2	
	4320.0	1200.0	72.5			82.0	5.2	
	5040.0	1400.0	65.0			88.5	6.2	
	2952.0	820.0	70.0			86.0	8.2	
	3960.0	1100.0	63.0			80.0	5.1	
	4680.0	1300.0	56.0			86.0	6.0	
FS500-870	A	2520.0	700.0	180.0	2500	860	81.0	4.1
		3744.0	1040.0	160.0			87.5	5.2
		4320.0	1200.0	148.0			86.0	7.0
		2520.0	700.0	153.5			82.5	4.2
		3384.0	940.0	140.0			87.0	5.0
		3960.0	1100.0	127.0			85.5	6.5
	B	2520.0	700.0	180.0	1800	757	81.0	4.1
		3744.0	1040.0	160.0			87.5	5.2
		4320.0	1200.0	148.0			86.0	7.0
		2520.0	700.0	153.5			82.5	4.2
		3384.0	940.0	140.0			87.0	5.0
		3960.0	1100.0	127.0			85.5	6.5

FS

DATA

DOUBLE SUCTION CENTRIFUGAL PUMP

FS SERIES / 单级双吸离心泵
FS系列

VIII、PERFORMANCE DATA 性能参数

(Type) 泵型号		(Capacity) 流量		Head扬程 (m)	Speed转速 (r/min)	Motor power 电机功率 (Kw)	Eff效率 (%)	叶轮直径 (mm)	汽蚀余量 (NPSH) (m)	
		(m³/h)	(L/s)							
FS500-1015	B	2160.0	600.0	135.0	985	1400	80.0	893	4.1	
		3024.0	840.0	120.0			86.0		5.2	
		3600.0	1000.0	110.0			85.0		6.5	
	C	2160.0	600.0	116.0		80.0	837	4.1		
		2880.0	800.0	105.0		85.5		5.0		
		3240.0	900.0	97.5		84.0		6.0		
FS500-1050	A	3240.0	900.0	183.0	985	3000	80.0	1035	5.1	
		5184.0	1440.0	160.0			89.0		6.5	
		6480.0	1800.0	137.0			84.0		10.2	
		2916.0	810.0	157.0			80.0		5.1	
		4680.0	1300.0	130.0			88.0		6.2	
		6120.0	1700.0	113.5			82.0		11.5	
	B	2880.0	800.0	136.0		2500	971	80.0	910	5.2
		4320.0	1200.0	120.0				88.0		6.4
		5400.0	1500.0	101.0				82.0		9.8
		2880.0	800.0	116.5				80.0		5.2
		3960.0	1100.0	106.0				84.5		6.2
		4860.0	1350.0	88.0				80.0		9.0
FS600-560	A	3600.0	1000.0	31.5	985	450	80.0	570/553	5.3	
		4716.0	1310.0	26.0			87.0		7.8	
		5400.0	1500.0	21.0			80.0		10.5	
		3330.0	925.0	29.5			80.0		5.1	
		4428.0	1230.0	23.0			85.0		7.6	
		5400.0	1500.0	17.0			83.0		12.6	
	B	3240.0	900.0	24.0		280	508/492	79.0	480/460	5.1
		4050.0	1125.0	19.0				83.0		7.2
		1950.0	537.5	14.0				82.0		11.2
		2700.0	750.0	22.0				72.0		4.6
		3600.0	1000.0	17.0				81.0		6.2
		4320.0	1200.0	12.5				78.0		7.8
FS600-600	A	3780.0	1050.0	46.0	985	710	80.0	600	5.3	
		5580.0	1550.0	37.0			90.0		7.0	
		6912.0	1920.0	26.0			82.0		10.8	
		3960.0	1100.0	37.0			82.0		5.4	
		5400.0	1500.0	30.0			88.0		6.9	
		6480.0	1800.0	22.0			81.0		10.0	
	B	3960.0	1100.0	30.0		450	528	81.0	582	5.4
		5040.0	1400.0	25.5				85.5		6.8
		6120.0	1700.0	18.0				78.0		9.8
		3960.0	1100.0	25.0				80.5		5.5
		4680.0	1300.0	22.0				82.0		6.4
		5400.0	1500.0	18.0				80.0		8.0
FS600-630	A	3330.0	925.0	49.0	990	710	80.0	620	4.3	
		4500.0	1250.0	42.5			89.0		5.4	
		5670.0	1575.0	32.5			80.0		9.8	
		3150.0	875.0	43.0			82.0		4.3	
		4320.0	1200.0	36.5			88.0		5.6	
		5310.0	1475.0	27.0			80.0		9.0	
	B	3150.0	875.0	35.5		450	550	82.0	585	4.3
		4050.0	1125.0	29.6				86.0		5.7
		4950.0	1375.0	22.0				79.0		8.0
		2700.0	750.0	28.0				76.0		4.3
		3600.0	1000.0	25.0				84.0		5.0
		4500.0	1250.0	17.3				79.0		7.4
FS600-705	A	3600.0	1000.0	69.5	985	1120	80.0	705	5.1	
		5580.0	1550.0	58.0			90.5		7.0	
		6840.0	1900.0	47.5			85.0		10.2	
		3600.0	1000.0	58.0			80.0		5.2	
		5040.0	1400.0	50.0			89.0		6.3	
		6480.0	1800.0	39.0			82.5		10.0	
	B	2880.0	800.0	51.0		710	661	72.0	620	5.2
		4680.0	1300.0	42.5				88.0		6.5
		5760.0	1600.0	35.0				83.0		9.0
		2880.0	800.0	43.0				71.0		5.2
		4320.0	1200.0	37.0				86.0		6.0
		5400.0	1500.0	29.0				80.0		8.5

DOUBLE SUCTION CENTRIFUGAL PUMP

FS SERIES / 单级双吸离心泵
FS系列

(Type) 泵型号		(Capacity) 流量		Head扬程 (m)	Speed转速 (r/min)	Motor power 电机功率 (Kw)	Eff效率 (%)	叶轮直径 (mm)	汽蚀余量 (NPSH) (m)	
		(m³/h)	(L/s)							
FS600-710	A	2880.0	800.0	69.0	960	900	80.0	715	4.0	
		4626.0	1285.0	58.5			89.0		6.5	
		5400.0	1500.0	51.5			87.0		11.0	
		2880.0	800.0	59.0			81.0		4.0	
		4320.0	1200.0	50.0			87.0		5.6	
		5400.0	1500.0	40.0			82.0		11.0	
	B	2880.0	800.0	51.0		800	630	81.0	640	4.0
		4050.0	1125.0	43.0				85.0		5.0
		5040.0	1400.0	33.0				81.0		8.6
		2880.0	800.0	41.0				81.0		4.0
		3744.0	1040.0	35.0				83.0		4.5
		4680.0	1300.0	26.8				78.0		6.8
FS600-860	A	4320.0	1200.0	126.0	994	2240	86.0	910	5.0	
		6660.0	1850.0	102.6			90.0		8.7	
		7920.0	2000.0	96.0			88.0		12.0	
		4320.0	1200.0	110.0			87.0		5.2	
		6120.0	1700.0	93.0			89.0		8.6	
		6840.0	1900.0	85.0			87.0		13.0	
	B	4320.0	1200.0	93.0		2000	1800	84.0	820	6.4
		5400.0	1500.0	84.0				87.0		8.2
		6480.0	1800.0	74.0				84.0		13.5
		3600.0	1000.0	85.0				77.0		5.0
		5040.0	1400.0	75.0				86.0		7.8
		6120.0	1700.0	67.0				84.0		14.0
FS600-885	A	4500.0	1250.0	114.0	985	2400	85.0	885	5.8	
		6480.0	1800.0	100.0			91.0		7.2	
		8100.0	2250.0	82.5			85.0		11.5	
		4500.0	1250.0	96.0			85.0		5.9	
		5940.0	1625.0	87.0			90.0		7.1	
		7200.0	2000.0	74.0			86.0		10.0	
	B	3600.0	1000.0	85.0		1400	1800	78.0	779	5.5
		5400.0	1500.0	74.5				89.0		6.9
		6300.0	1750.0	66.0				86.0		9.0
		3600.0	1000.0	73.0				78.0		5.6
		4950.0	1375.0	65.0				88.0		6.6
		6300.0	1750.0	52.0				81.0		10.2
FS600-1075	A	4500.0	1250.0	190.0	985	4000	85.0	1075	5.7	
		6480.0	1800.0	170.0			90.5		7.2	
		8100.0	2250.0	144.0			85.0		11.8	
		3600.0	1000.0	168.0			80.0		5.5	
		5940.0	1650.0	149.0			90.0		7.2	
		7200.0	2000.0	128.0			85.0		10.0	
	B	3600.0	1000.0	144.0		2500	2000	80.0	946	5.6
		5400.0	1500.0	127.0				88.5		7.1
		6750.0	1875.0	106.0				82.0		11.0
		3600.0	1000.0	123.0				80.0		5.7
		4950.0	1375.0	111.0				86.0		6.9
		5940.0	1625.0	98.0				83.0		9.0
FS700-600	A	5040.0	1400.0	35.4	980	710	81.0	565	5.7	
		6480.0	1800.0	30.0			87.0		8.2	
		7560.0	2100.0	25.0			82.0		11.5	
		5040.0	1400.0	32.0			81.0		5.7	
		6336.0	1760.0	27.0			85.0		7.0	
		7200.0	2000.0	24.0			82.0		10.0	
	B	5040.0	1400.0	29.0		630	560	81.0	535/515	5.7
		6120.0	1700.0	26.0				83.0		7.3
		7200.0	2000.0	22.0				80.0		10.0
		4320.0	1200.0	28.0				82.0		5.1
		5904.0	1640.0	24.0				81.0		6.8
		6840.0	1900.0	20.6				77.0		9.0
FS700-710	A	4680.0	1300.0	54.0	960	1000	75.0	706/694	6.2	
		6516.0	1800.0	44.0			87.0		8.0	
		8470.0	2200.0	33.0			82.0		11.4	
		4680.0	1300.0	48.0			81.0		6.2	
		6264.0	1740.0	40.0			85.0		7.0	
		7380.0	2050.0	32.0			83.0		9.4	
	B	4680.0	1300.0	44.0		900	710	80.0	680/670	6.2
		5976.0	1660.0	36.5				83.0		7.3
		7200.0	2000.0	28.0				80.0		9.2
		4680.0	1300.0	40.0				79.0		6.2
		5760.0	1600.0	33.5				81.0		7.0
		6840.0	1900.0	26.0				79.0		8.5

FS

DATA

DOUBLE SUCTION CENTRIFUGAL PUMP

FS SERIES / 单级双吸离心泵
FS系列

VIII、PERFORMANCE DATA 性能参数

(Type) 泵型号	(Capacity) 流量		Head扬程 (m)	Speed转速 (r/min)	Motor power 电机功率 (Kw)	Eff效率 (%)	叶轮直径 (mm)	汽蚀余量 (NPSH) (m)		
	(m³/h)	(L/s)								
FS700-800	A	5040.0	1400.0	92.0	2000	83.0	835	5.6		
		7380.0	2050.0						80.0	
		8640.0	2400.0						70.0	
		4680.0	1300.0						80.0	
		6984.0	1940.0						68.0	
		8280.0	2300.0						57.0	
	B	4680.0	1300.0	68.0	1800	81.0	790	5.6		
		6552.0	1820.0	58.0						
		8280.0	2300.0	44.0						
		4680.0	1300.0	56.0						
		6012.0	1670.0	48.0						
		7200.0	2000.0	38.8						
FS700-980	A	6480.0	1800.0	132.0	1800	83.0	980	7.0		
		8640.0	2400.0						117.0	
		10080.0	2800.0						103.0	
		5760.0	1600.0						115.0	
		7920.0	2200.0						100.0	
		9360.0	2600.0						88.0	
	B	5760.0	1600.0	96.0	1400	89.0	919	6.6		
		7200.0	2000.0	87.5						
		8640.0	2400.0	75.0						
		5760.0	1600.0	81.0						
		6840.0	1900.0	74.0						
		7560.0	2100.0	67.5						
FS700-980	C	4500.0	1250.0	82.5	1000	85.0	808	8.3		
		6840.0	1900.0						74.0	
		7560.0	2100.0						67.5	
		4500.0	1250.0						82.5	
		7560.0	2100.0						70.0	
		9000.0	2500.0						60.5	
	A	4500.0	1250.0	70.0	1800	91.5	980	5.5		
		6840.0	1900.0	60.0						
		8550.0	2375.0	50.0						
		4500.0	1250.0	59.0						
		6300.0	1750.0	52.0						
		8100.0	2250.0	40.5						
FS800-800	B	4500.0	1250.0	50.0	1000	87.5	809	5.0		
		5940.0	1625.0						45.0	
		7200.0	2000.0						37.5	
		7200.0	2000.0						33.0	
		9000.0	2500.0						27.0	
		10800.0	3000.0						19.0	
	A	6480.0	1800.0	31.2	900	86.0	790/770	7.0		
		8640.0	2400.0	24.3						
		10080.0	2800.0	16.6						
		6480.0	1800.0	28.0						
		8280.0	2300.0	22.3						
		9720.0	2700.0	15.3						
FS800-800	B	6480.0	1800.0	28.0	800	85.0	757/730	7.3		
		8280.0	2300.0						16.6	
		9720.0	2700.0						15.3	
		6480.0	1800.0						28.0	
		8280.0	2300.0						22.3	
		9720.0	2700.0						15.3	
	FS800-900	C	5760.0	1600.0	26.2	710	84.0	723/690	6.0	
			7920.0	2200.0						19.8
			9360.0	2600.0						13.0
			5760.0	1600.0						26.2
			7920.0	2200.0						19.8
			9360.0	2600.0						13.0
FS800-900		A	7200.0	2000.0	51.6	1400	84.0	885	5.1	
			9000.0	2500.0						46.0
			10800.0	3000.0						38.5
			6840.0	1900.0						48.0
			8640.0	2400.0						42.2
			10080.0	2800.0						36.5
	B	6480.0	1800.0	43.6	1250	86.0	850	6.1		
		8280.0	2300.0	38.5						
		10440.0	2900.0	30.4						
		6480.0	1800.0	43.6						
		8280.0	2300.0	38.5						
		10440.0	2900.0	30.4						
FS800-900	C	5760.0	1600.0	41.0	1120	85.0	810	5.6		
		7920.0	2200.0						35.0	
		10080.0	2800.0						27.0	
		5760.0	1600.0						41.0	
		7920.0	2200.0						35.0	
		10080.0	2800.0						27.0	
	D	5760.0	1600.0	36.0	1000	84.0	775	5.4		
		7452.0	2070.0	31.0						
		9360.0	2600.0	25.6						
		5760.0	1600.0	36.0						
		7452.0	2070.0	31.0						
		9360.0	2600.0	25.6						

DOUBLE SUCTION CENTRIFUGAL PUMP

FS SERIES / 单级双吸离心泵
FS系列

(Type) 泵型号	(Capacity) 流量		Head扬程 (m)	Speed转速 (r/min)	Motor power 电机功率 (Kw)	Eff效率 (%)	叶轮直径 (mm)	汽蚀余量 (NPSH) (m)	
	(m³/h)	(L/s)							
FS800-990	A	7200.0	2000.0	72.0	2240	83.0	980	4.2	
		9468.0	2630.0						64.0
		11520.0	3200.0						52.0
		6480.0	1800.0						65.6
		9396.0	2610.0						56.0
		11160.0	3100.0						44.7
	B	6120.0	1700.0	59.5	1800	81.0	940	4.0	
		8640.0	2400.0	50.5					
		10440.0	2900.0	41.0					
		6120.0	1700.0	52.7					
		8280.0	2300.0	45.0					
		9720.0	2700.0	38.5					
FS900-970	A	7920.0	2200.0	28.6	800	82.0	1000	3.5	
		10134.0	2815.0						24.0
		13680.0	3800.0						17.5
		7920.0	2200.0						26.5
		10134.0	2815.0						22.0
		12960.0	3600.0						17.2
	A	8640.0	2400.0	44.0	800	80.0	990/970	4.0	
		12204.0	3390.0	36.5					
		15660.0	4800.0	20.6					
		8640.0	1900.0	41.0					
		12204.0	3390.0	33.0					
		16200.0	4500.0	20.0					
FS900-1030	A	8640.0	2400.0	33.0	1400	80.0	990/970	5.0	
		11520.0	3200.0						28.0
		15120.0	4200.0						18.5
		8640.0	2400.0						33.0
		11520.0	3200.0						28.0
		15120.0	4200.0						18.5
	A	10800.0	3000.0	49.0	1120	87.0	1050	5.2	
		13860.0	3850.0	41.0					
		17280.0	4800.0	32.0					
		10800.0	3000.0	49.0					
		13860.0	3850.0	41.0					
		17280.0	4800.0	32.0					
FS900-1050	A	8640.0	2400.0	43.5	490	87.0	1155	3.5	
		11520.0	3200.0						38.0
		14040.0	3900.0						30.0
		8640.0	2400.0						43.5
		11520.0	3200.0						38.0
		14040.0	3900.0						30.0
	A	10800.0	3000.0	62.0	1400	87.5	1155	5.6	
		13680.0	3800.0	55.0					
		17280.0	4800.0	43.0					
		10800.0	3000.0	62.0					
		13680.0	3800.0	55.0					
		17280.0	4800.0	43.0					
FS1000-1170	A	11340.0	3150.0	21.7	900	88.0	1170	2.8	
		14040.0	3900.0						18.4
		16740.0	4650.0						13.4
		9720.0	2700.0						20.5
		12960.0	3600.0						17.2
		16200.0	4500.0						11.7
	A	12960.0	3600.0	40.0	800	87.0	1150/1080	2.8	
		18360.0	5100.0	31.5					
		22140.0	6150.0	22.5					
		12960.0	3600.0	35.6					
		16236.0	4510.0	31.1					
		19440.0	5400.0	24.5					
FS1000-1170	A	12960.0	3600.0	40.0	1800	88.0	1170	4.8	
		18360.0	5100.0						31.5
		22140.0	6150.0						22.5
		12960.0	3600.0						35.6
		16236.0	4510.0						31.1
		19440.0	5400.0						24.5
	A	12960.0	3600.0	40.0	1600	83.5	1150/1080	9.2	
		18360.0	5100.0	31.5					
		22140.0	6150.0	22.5					
		12960.0	3600.0	35.6					
		16236.0	4510.0	31.1					
		19440.0	5400.0	24.5					

FS

DATA

DOUBLE SUCTION CENTRIFUGAL PUMP

FS SERIES / 单级双吸离心泵
FS系列

IX、PERFORMANCE DATA 法兰尺寸图

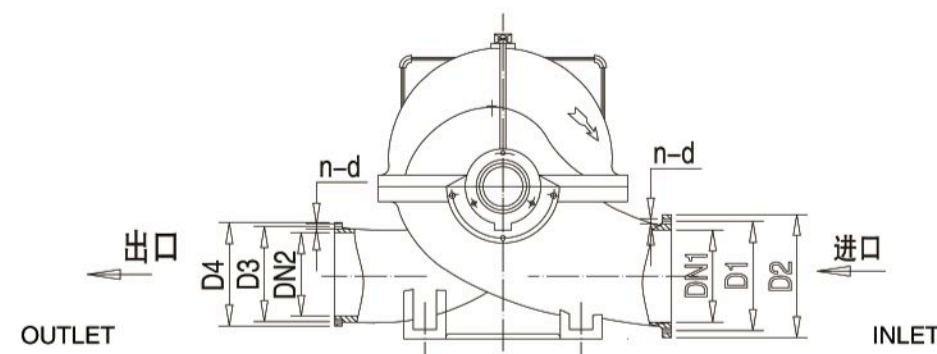

法兰尺寸图

Pump type 泵型号	Inlet dia 进口口径		Inlet flange size 进口法兰尺寸		Outlet dia 出口口径		Outlet flange size 出口法兰尺寸	
	DN1	D1	D2	n-d	DN2	D2	D4	n-d
FS80-210	125	210	279	8-Φ18	80	160	210	8-Φ18
FS80-270	125	210	279	8-Φ18	80	160	210	8-Φ18
FS80-370	125	210	270	8-Φ18	80	160	185	8-Φ18
FS100-250	150	240	318	8-Φ23	100	180	254	8-Φ18
FS100-310	150	240	300	8-Φ23	100	180	230	8-Φ18
FS100-375	150	240	318	8-Φ23	100	180	254	8-Φ18
FS125-230	200	295	365	12-Φ23	125	210	275	8-Φ18
FS125-290	200	295	365	12-Φ23	125	210	272	8-Φ18
FS125-365	200	295	365	12-Φ23	125	210	275	8-Φ18
FS125-500	200	295	381	12-Φ23	125	210	279	8-Φ18
FS150-290	200	295	365	12-Φ23	150	240	300	8-Φ23
FS150-360	200	295	360	12-Φ23	150	240	300	8-Φ23
FS150-450	200	295	365	12-Φ23	150	240	300	8-Φ23
FS150-605	200	310	365	12-Φ25	150	250	300	8-Φ25
FS200-320	250	355	425	12-Φ23	200	295	365	12-Φ23
FS200-420	250	355	425	12-Φ23	200	295	356	12-Φ23
FS200-520	250	355	445	12-Φ26	200	295	381	12-Φ22
FS200-670	250	370	430	12-Φ30	200	310	365	12-Φ26
FS250-370	300	410	470	12-Φ26	250	355	445	12-Φ26
FS250-480	300	410	485	12-Φ26	250	355	425	12-Φ26
FS250-600	300	410	485	12-Φ26	250	355	445	12-Φ26
FS300-300	350	460	550	16-Φ22	300	400	485	12-Φ22

DOUBLE SUCTION CENTRIFUGAL PUMP

FS SERIES / 单级双吸离心泵
FS系列

Pump type 泵型号	Inlet dia 进口口径		Inlet flange size 进口法兰尺寸		Outlet dia 出口口径		Outlet flange size 出口法兰尺寸	
	DN1	D1	D2	n-d	DN2	D2	D4	n-d
FS300-435	400	525	580	16-Φ30	300	410	460	12-Φ26
FS300-560	400	525	580	16-Φ30	300	410	460	12-Φ26
FS300-700	400	550	610	16-Φ36	300	430	485	12-Φ30
FS350-360	400	525	597	16-Φ30	350	470	533	16-Φ26
FS350-430	450	585	649	16-Φ30	350	470	533	16-Φ26
FS400-560	500	585	705	20-Φ34	400	525	580	16-Φ30
FS400-600	500	620	670	20-Φ31	400	525	580	16-Φ30
FS400-665	500	650	715	20-Φ36	400	525	580	16-Φ30
FS400-675	500	660	730	20-Φ37	400	550	620	16-Φ31
FS400-705	500	660	730	20-Φ37	400	550	620	16-Φ31
FS400-900	500	660	730	20-Φ41	400	550	620	16-Φ34
FS400-935	500	686	775	24-Φ35	400	572	650	20-Φ34
FS500-520	600	770	840	20-Φ34	500	650	715	20-Φ34
FS500-585	600	725	780	20-Φ30	500	620	670	20-Φ27
FS500-650	600	725	780	20-Φ30	500	620	670	20-Φ27
FS500-685	600	725	780	20-Φ30	500	620	670	20-Φ27
FS500-710	600	725	780	20-Φ30	500	620	670	20-Φ27
FS500-800	600	770	840	20-Φ34	500	650	715	20-Φ34
FS500-835	600	770	840	20-Φ34	500	650	715	20-Φ34
FS500-860	600	725	780	20-Φ30	500	650	705	20-Φ34
FS500-870	600	770	840	20-Φ34	500	650	715	20-Φ34
FS500-1015	600	770	845	20-Φ39	500	660	730	20-Φ36
FS500-1050	600	770	845	20-Φ39	500	660	730	20-Φ36
FS600-560	700	840	910	24-Φ36	600	770	840	20-Φ36
FS600-600	700	840	910	24-Φ36	600	770	840	20-Φ36
FS600-630	700	840	910	24-Φ36	600	770	840	20-Φ36
FS600-705	700	840	910	24-Φ36	600	770	840	20-Φ36
FS600-710	700	840	895	24-Φ30	600	725	780	20-Φ36
FS600-860	700	840	910	24-Φ36	600	770	840	20-Φ36
FS600-885	700	840	910	24-Φ36	600	770	840	20-Φ36
FS600-1075	700	875	910	24-Φ37	600	770	845	20-Φ39
FS700-600	800	950	1025	24-Φ34	700	840	910	24-Φ36
FS700-710	800	950	1025	24-Φ34	700	840	910	24-Φ36
FS700-800	800	950	1025	24-Φ34	700	840	910	24-Φ36
FS700-980	800	950	1025	24-Φ34	700	840	910	24-Φ36
FS800-800	900	1050	1125	28-Φ34	800	950	1025	24-Φ34
FS800-900	900	1050	1125	28-Φ34	800	950	1025	24-Φ34

FS

DIMENSION

DOUBLE SUCTION CENTRIFUGAL PUMP

FS SERIES / 单级双吸离心泵
FS系列

主要外形尺寸 (配 Y 型电机)

Overall size(Y serial motor)

80-210

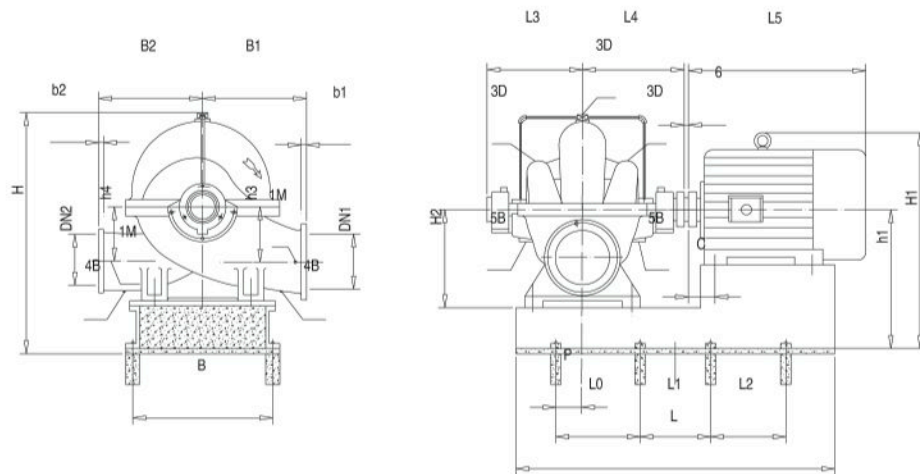

连接螺纹尺寸
Connect nut size

1M	真空表 Vacuum meter	R1/2
2M	压力表 Pressure meter	R1/2
3D	排气孔 Vent	R1/2
4B	排水孔 scupper	R1/2
5B	漏液排出孔 Leakage vent	R3/4

泵型号 Pump type		法兰尺寸 flange size				泵尺寸 pump size							泵质量 weight(kg)		
		DN1	DN2	b1	b2	B1	B2	L4	H≤	L3	H2	h3	h4		
FS80-210						300	300				315	140	140	278	
FS80-270		125	80	26	24						315	140	140	293	
FS80-370						330	330	443	600	336	315	140	140	308	
电机极数 Motor pole	泵型号 Pump type	电机型号 Motor type	电机功率 motor power (kw)	B	h1	H1	L	L0		L1	P	L5	电机重量 motor weight (Kg)	底座参考重量 base weight (kg)	
4	FS80-370	FS810-270	100L	2.2-3	340	435	580	880				70	380	39	70
			100M	4			288	890			400		45		
			132S	5.5			618	930			475		72		
			132M	7.5				970			515		84		
			160M	11			660	1050			605		130		
			160L	15				1135			650		144		
			180M	18.5			660	1150			670		180		
			180L	22				1180			710		195		
			160L	18.5				660	1100		450		650	150	
			160M	22			340	435	685	1100	455		710	182	
200L	30			710	1190	495	775	255							
225M	45	356		765	1230	515	815	325							
250M	55			785	1310	560	930	395							
280S	75	457	460	820	1410	595	1000	500							

DOUBLE SUCTION CENTRIFUGAL PUMP

FS SERIES / 单级双吸离心泵
FS系列

泵型号 Pump type		法兰尺寸 flange size				泵尺寸 pump size							泵质量 weight(kg)		
		DN1	DN2	b1	b2	B1	B2	L4	H≤	L3	H2	h3	h4		
FS100-250						330	330	443	760	336	355	170	170	315	
FS100-310		150	100	28	24						355	170	170	338	
FS100-375						370	370				355	170	170	368	
电机极数 Motor pole	泵型号 Pump type	电机型号 Motor type	电机功率 motor power (kw)	B	h1	H1	L	L0		L1	P	L5	电机重量 motor weight (Kg)	底座参考重量 base weight (kg)	
4	FS100-375	FS100-250	132S	5.5	400	475	658	930				70	475	72	80
			132M	7.5				970			515		84		
			160M	11			700	1090			605		130		
			160L	15				1100			650		145		
			180M	18.5				1140			670		480		
			180L	22			725	1180			710		200		
			200L	30				750	1190		775		270		
			225S	37				780	1220		820		284		
			225M	45					1270		845		320		
			220L	37			400	475	750	1190	495		775	255	
225M	45			780	1245	505	815	308							
250M	55	406			1320	560	930	403							
280S	75			825	1410	595	1000	544							
280M	90	457			1440	620	1050	620							
315S	110			860	1480	640	1240	980							
315M	132	508	500	1050	1550	665	1310	1080							
315L	200				1605	680	1310	1220							

泵型号 Pump type		法兰尺寸 flange size				泵尺寸 pump size							泵质量 weight(kg)		
		DN1	DN2	b1	b2	B1	B2	L4	H≤	L3	H2	h3	h4		
FS125-230						370	370	517.5	825	366	400	200	200	375	
FS125-290		200	125	30	26						400	200	200	413	
FS125-365						450	450				400	200	200	450	
FS125-500						450	450				400	200	200	503	
电机极数 Motor pole	泵型号 Pump type	电机型号 Motor type	电机功率 motor power (kw)	B	h1	H1	L	L0		L1	P	L5	电机重量 motor weight (Kg)	底座参考重量 base weight (kg)	
4	FS125-365	FS125-230	132M	7.5	450	520	703	1100				105	515	84	80
			160M	11			745	1190			605		130		
			160L	15				1240			650		145		
			180M	18.5				1250			670		180		
			180L	22				770	1250		710		200		
			200L	30					540		775		270		
			225S	37				795	1300		820		284		
			225M	45					1340		845		320		
			250M	55				845	1440	620	930		427		
			280S	75			457	545	905	1520	660		1000	562	
225S	37			825	1350	575	820	284							
225M	45				1380	590	845	320							
250M	55			845	1440	620	930	427							
280S	75	560	520	880	1510	655	1000	562							
280M	90				1575	680	1050	667							
315S	110			1071	1630	715	1270	1000							
280S	75	487			1520	660	1000	544							
280M	90			905	1580	690	1050	620							
315S	110	508	545		1620	710	1240	980							
315M	132			1095	1670	735	1310	1080							
315L	160-200	560			1700	750	1310	1200							
355M	220-250	640	520		1840	800	1540	1350							

DOUBLE SUCTION CENTRIFUGAL PUMP

FS SERIES / 单级双吸离心泵 FS系列

泵型号 Pump type	法兰尺寸 flange size				泵尺寸 pump size								泵质量 weight(kg)	
	DN1	DN2	b1	b	B1	B2	L4	H≤	L3	H2	h3	h4		
FS150-290	200	150	30	28	400	400	518	1050	365	400	200	200	521	
FS150-360					400	200	200		539					
FS150-450					450	450	592		421	400	200	200	654	
FS150-605					600	500			400	300	300	969		
电机极数 Motor pole	泵型号 Pump type	电机型号 Motor type	电机功率 motor power (kw)	B	h1	H1	L	L0	L1	L2	P	L5	电机重量 motor weight (Kg)	底座参考重量 base weight (kg)
4	FS150-290	180M	18.5	450	520	770	1240	520	105	670	180	115	180	115
		180L	22			1280	540	710		200				
		200L	30			795	1320	560		775	270			
		225S	37			825	1350	575		820	284			
		225M	45			845	1390	590		845	320			
		250M	55			845	1450	620		930	427			
	FS150-360	280S	75	457	545	905	1520	660	120	1000	562	190	562	190
		200L	30	795	1450	625	775	270						
		225S	37	825	1470	635	820	284						
		225M	45	845	1500	650	845	320						
		250M	55	845	1560	680	930	427						
		280S	75	880	1640	715	1000	562						
		280M	90	880	1680	740	1050	667						
		315S	110	1070	1760	775	1270	1000						
		315M	132	1800	800	1340	1100	144						
		315S	110	1750	775	1270	1000	149						
		315M	132	1800	800	1340	1100	252						
		315L	160-200	1830	815	1340	1240	252						
	355(6KV)	200-250	660	1105	2575	720	1820		3160	392				

泵型号 Pump type	法兰尺寸 flange size				泵尺寸 pump size								泵质量 weight(kg)	
	DN1	DN2	b1	b	B1	B2	L4	H≤	L3	H2	h3	h4		
FS200-320	250	200	36	30	450	450	592	1240	421	500	240	240	675	
FS200-420					500	240	240		776					
FS200-520					600	300	300		1260					
FS200-670					650	350	350		1485					
电机极数 Motor pole	泵型号 Pump type	电机型号 Motor type	电机功率 motor power (kw)	B	h1	H1	L	L0	L1	L2	P	L5	电机重量 motor weight (Kg)	底座参考重量 base weight (kg)
4	FS200-320	225S	37	560	620	925	1480	635	150	820	284	173	284	173
		225M	45			1500	650	845		320				
		250M	55			945	1570	680		930	427			
		280S	75			980	1640	715		1000	562			
		280M	90			980	1690	740		1050	667			
		315S	110			1170	1760	775		1270	1000			
	FS200-420	315M	132	1810	800	1340	1100	280						
		315S	110	1810	805	1270	1000							
		315M	132	1290	1860	830	1340		1100					
		315L	160	1910	845	1340	1240							
		250	250	1205	2640	750	1820		2000					
		355(6KV)	280	1205	2640	750	1820		2000					
		315	315	1205	2640	750	1820		2000					
		FS200-520	355	280-315	700	800	1330		2080	915	150	1340	1240	326
			355(6kv)	250-315	700	800	2450		750	150	1820	2160	410	
			400(6kv)	355-450	710	800	1205		2750	790	--	--	--	440

DOUBLE SUCTION CENTRIFUGAL PUMP

FS SERIES / 单级双吸离心泵 FS系列

泵型号 Pump type	法兰尺寸 flange size				泵尺寸 pump size								泵质量 weight(kg)			
	DN1	DN2	b1	b	B1	B2	L4	H≤	L3	H2	h3	h4				
FS250-370	300	250	51	48	500	500	655	1275	464	600	300	300	998			
FS250-480					550	550	731		516	600	300	300	1245			
FS250-600					650	700	786		1260	595	630	350	350	1823		
FS250-800					800	700					710	400	400			
电机极数 Motor pole	泵型号 Pump type	电机型号 Motor type	电机功率 motor power (kw)	B	h1	H1	L	L0	L1	L2	P	L5	电机重量 motor weight (Kg)	底座参考重量 base weight (kg)		
4	FS250-370	280S	75	700	780	1140	1690	745	150	1000	562	250	562	250		
		280M	90				1750	775		1050	667					
		315S	110				1810	805		1270	1000					
		315M	132				1330	1860		830	1340		1100			
		315L	160				1920	845		1340	1240					
		315S	110				1950	870		1270	1000					
	FS250-480	315M	132	700	800	1350	2000	900	210	1340	1100	410				
		315L	200	2030	915	1340	1240									
		335(6kv)	220-280	700	830	1225	2570	790	1620	2160	410					
		315L	200	1380	2030	915	1340	1240	410							
		335(6kv)	250-315	700	830	1225	2570	790	1820	2160	440					
		400(6kv)	400-560	710	860	1295	2720	840	210	1940	2620	585				
	FS250-600	450 (10kV)	315	900	830	1680	3120	970	210	1940	2620	585				
		500 (10kV)	560	1000	880	1900	3340	1020								
		FS250-800	500(6KV)	1120	1140	960	1980	3340					1020	210	1940	4500

泵型号 Pump type	法兰尺寸 flange size				泵尺寸 pump size								泵质量 weight(kg)	
	DN1	DN2	b1	b	B1	B2	L4	H≤	L3	H2	h3	h4		
FS300-300	350	300	54	51	500	500	655	1430	464	630	300	300	945	
FS300-435					650	550	731		516	670	360	360	1358	
FS300-560					700	650	810		596	710	350	350	2138	
FS300-700					750	650					750	400	400	2535
电机极数 Motor pole	泵型号 Pump type	电机型号 Motor type	电机功率 motor power (kw)	B	h1	H1	L	L0	L1	L2	P	L5	电机重量 motor weight (Kg)	底座参考重量 base weight (kg)
4	FS300-300	225S	37	700	810	1540	670	150	820	284	190	284	190	
		225M	45				1560		680	845		320		
		250M	55				945		1570	680		930		427
		280S	75				980		1640	715		1000		562
		280M	90				980		1690	740		1050		667
		315S	110				1170		1760	775		1270		1000
	FS300-435	315M	132	1810	800	1340	1100	285						
		315S	110	1810	805	1270	1000							
		315L	160-200	700	850	1340	1840		805					
		450(10KV)	280-315	920	870	1970	3040		930					
		355(6KV)	355-560	950	910	1335	2660		820					
		400(6KV)	400-560	950	910	1345	2780		860					
	FS300-560	400(6KV)	400-560	950	910	1385	2780	860	210	1940	2620	480		
		450(6KV)	630-900	950	950	1435	2900	900	210	2080	3850	480		
		500(6KV)	1120	950	950	1490	3200	1000	210	2550	4420	520		

FS

DIMENSION

DOUBLE SUCTION CENTRIFUGAL PUMP

FS SERIES / 单级双吸离心泵
FS系列

350-360

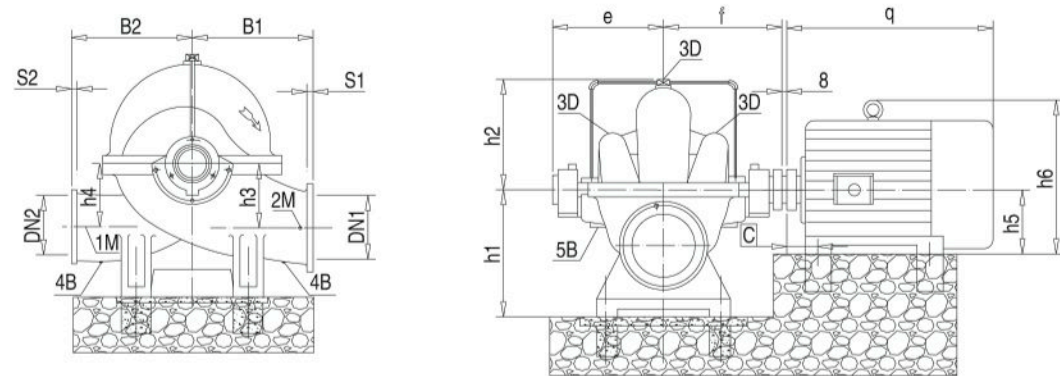

Connect nut size
连接螺纹尺寸

1M	Vacuum meter 真空表	R1/2
2M	Pressure meter 压力表	R1/2
3D	Vent 排气孔	R1
4B	scupper 排水孔	R1
5B	Leakage vent 漏液排出孔	R1

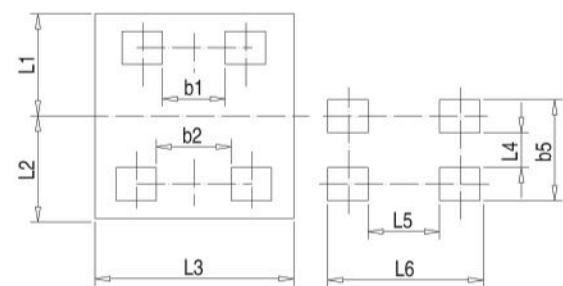

Pump type 泵型号	Flange size 法兰尺寸				Pump size 泵尺寸														Pump weight(kg) 泵质量	
	DN1	DN2	S1	S2	B1	B2	e	f	h1	h2	h3	h4	L1	L2	L3	b1	b2	b3		b4
FS350-360	400	350	57	54	650	550	516	731	670	490	350	350	400	400	600	180	180	300	300	
FS350-430	450	350	60.5	54	750	650	596	810	750	545	400	400	525	525	600	160	160	425	425	
FS350-510	400	350	57	51	700	650	596	810	750	500	400	400	525	525	600	160	160	425	425	
FS350-575	400	350	32	30	900	700	720	956	900	550	475	475	560	560	780	480	480	410	410	2600
FS350-630	400	350	38	36	740	670	660	860	775	515	460	460	615	675	1040	320	580	255	315	2630
FS350-690	400	350	38	36	900	750	720	956	900	550	475	475	560	560	780	480	480	410	410	2750

Motor pole 电机极数	Pump type 泵型号	Motor type 电机型号	Motor power(Kw) 电机功率	L4	L5	b5	b6	h5	h6	c	q	Motor weight(kg) 电机重量		
4	FS350-360	315S	110	388	203	628	609	315	865	388	1270	875		
		315M	132	836	759	180	155	315	195	426	1340	1025		
		315L1	160	388	305	628	711	315	865	388	1340	1135		
		315L2	200	388	305	628	711	315	865	388	1310	1190		
		FS350-430	355M1	220	480	290	740	830	355	1035	426	1540	1350	
			355L1	280	388	203	628	609	355	865	358	1270	860	
			355L2	315	480	430	740	830	355	1035	388	1570	1650	
			FS350-510	4001	355	520	500	900	1500	400	1200	547	1910	2480
				4002	400	520	500	900	1500	400	1200	547	1910	2560
				4003	450	520	500	900	1500	400	1200	547	1910	2640
	4004			500	520	500	900	1500	400	1200	547	1910	2730	
	4005			560	520	500	900	1500	400	1200	547	1910	2880	
	FS350-575			4501	630	600	480	1000	1760	450	1350	567	2160	3550
				4502	710	600	480	1000	1760	450	1350	567	2160	3670
		FS350-630		4503	800	600	480	1000	1760	450	1350	567	2160	3930
			4504	900	600	480	1000	1760	450	1350	567	2160	3960	
	FS350-690	5001	1000	680	560	1120	1940	500	1520	772	2800	5680		
		5002	1120	680	560	1120	1940	500	1520	772	2800	5830		
		FS350-690	5004	1400	680	560	1120	1940	500	1520	772	2800	6220	

DOUBLE SUCTION CENTRIFUGAL PUMP

FS SERIES / 单级双吸离心泵
FS系列

FS

DIMENSION

pump type 泵型号	Flange size 法兰尺寸				Pump size 泵尺寸														Pump weight(kg) 泵质量	
	DN1	DN2	S1	S2	B1	B2	e	f	h1	h2	h3	h4	L1	L2	L3	b1	b2	b3		b4
400-525	500	400	34	32	750	700	747	998	990	550	475	475	560	560	890	590	590	410	410	2400
400-560	500	400	46	40	750	700	685	865	820	500	460	460	675	725	1130	420	670	275	325	2700
400-600	500	400	42	38	800	700	690	905	850	530	490	490	675	775	1130	420	670	275	375	2925
400-665	500	400	42	38	1000	750	747	998	1000	620	525	525	560	560	890	590	590	410	410	3200
400-675	500	400	42	38	900	800	660	854	900	580	450	450	640	640	730	630	630	330	330	
400-705	500	400	42	38	900	800	720	956	900	570	450	450	640	640	750	480	480	490	490	2800
400-900	500	400	52	48	1000	1000	736	1030	960	710	550	550	750	750	800	500	500	500	500	
400-935	500	400	44	40	1050	1000	720	956	1000	650	550	550	640	640	840	540	540	490	490	3100

Motor pole 电机极数	Pump type 泵型号	Motor type 电机型号	Motor power 电机功率	L4	L5	b5	b6	h5	h6	c	q	Motor weight (kg) 电机重量		
4	FS400-525	4003	450	520	500	900	1500	400	1200	547	1910	2640		
		4004	500	520	500	900	1500	400	1200	547	1910	2730		
		4005	560	520	500	900	1500	400	1200	547	1910	2880		
		FS400-560	4501	630	600	480	1000	1760	450	1350	567	2160	3550	
			4502	710	600	480	1000	1760	450	1350	567	2160	3670	
			4503	800	600	480	1000	1760	450	1350	567	2160	3930	
			4504	900	600	480	1000	1760	450	1350	567	2160	3960	
			FS400-600	5001	1000	680	560	1120	1940	500	1520	772	2800	5680
				5002	1120	680	560	1120	1940	500	1520	772	2800	5830
		5003		1250	680	560	1120	1940	500	1520	772	2800	6040	
	5601	1600		750	700	1250	2100	560	1800	812	2740	6550		
	FS400-665	FS400-525	355M1	160	480	290	740	830	355	1035	426	1570	1350	
			355M2	185	480	290	740	830	355	1035	426	1570	1400	
			355L1	220	388	203	628	609	355	865	358	1270	860	
			355L3	250	480	430	740	830	355	1035	426	1570	1650	
			4002	280	520	500	900	1500	400	1200	547	1910	2560	
		FS400-665	4003	315	520	500	900	1500	400	1200	547	1910	2640	
			4003	355	520	500	900	1500	400	1200	547	1910	2640	
			4005	400	520	500	900	1500	400	1200	547	1910	2880	
			4501	450	600	480	1000	1760	450	1350	567	2160	3550	
4503			560	600	480	1000	1760	450	1350	567	2160	3930		
FS400-705	FS400-525	5001	710	680	560	1120	1940	500	1520	727	2430	4660		
		5002	800	680	560	1120	1940	500	1520	727	2430	4830		
		5003	900	680	560	1120	1940	500	1520	727	2430	4930		
		5004	1000	680	560	1120	1940	500	1520	727	2430	5100		
		5601	1120	750	800	1250	2000	560	1800	752	2490	5900		
	FS400-935	5602	1250	750	800	1250	2000	560	1800	752	2490	6200		
		5603	1400	750	800	1250	2000	560	1800	752	2490	6500		
		6301	1600	840	800	1400	2400	630	2000	832	2930	8300		

DOUBLE SUCTION CENTRIFUGAL PUMP

FS SERIES / 单级双吸离心泵
FS系列

Pump type 泵型号	Flange size 法兰尺寸				Pump size 泵尺寸																Pump weight (kg) 泵质量
	DN1	DN2	S1	S2	B1	B2	e	f	h1	h2	h3	h4	L1	L2	L3	b1	b2	b3	b4		
FS500-520	600	500	48	42	850	850	770	975	900	560	475	475	460	610	1250	520	820	140	290	3042	
FS500-585	600	500	48	42	1100	800	847	1098	1100	680	550	550	640	640	1050	750	750	490	490	4400	
FS500-650	600	500	48	42	850	800	850	1065	920	600	495	495	660	660	1260	520	820	340	340	3452	
FS500-685	600	500	48	42	1100	800	847	1098	1100	670	575	575	640	640	1050	750	750	490	490	4300	
FS500-710	600	500	48	42	1050	850	835	1035	1000	620	550	620	710	810	1320	480	880	390	490	4451	
FS500-800	600	500	48	42	1000	900	850	1125	1050	660	600	600	760	860	1360	535	920	440	540	5225	
FS500-835	600	500	48	42	1150	1100	872	1166	1100	690	575	575	850	850	1070	670	670	650	650	4760	
FS500-860	600	500	48	42	1050	950	870	1160	1100	710	650	650	810	910	1260	560	820	490	590	6989	
FS500-870	600	500	48	42	1200	900	872	1166	1200	775	700	700	725	725	1070	670	670	525	525	5000	
FS500-1015	600	500	48	42	1200	1100	872	1166	1200	750	725	725	850	850	1070	670	670	650	650	5500	
FS500-1050	600	500	48	42	1250	1100	872	1166	1200	800	700	700	850	850	1070	670	670	650	650	5680	
Motor pole 电机极数	Pump type 泵型号				Motor type 电机型号	Motor power (Kw) 电机功率	L4	L5	b5	b6	h5	h6	c	q	Motor weight (kg) 电机重量						
	6	FS500-520	FS500-585	FS500-650	FS500-685	FS500-710	FS500-800	FS500-835	FS500-860	FS500-870	FS500-1015	355M2	185	480	290	740	830	355	1035	426	1570
355M3												200	480	290	740	830	355	1035	426	1570	1500
355L1												220	388	203	628	609	355	865	358	1270	860
355L3												250	480	430	740	830	355	1035	426	1570	1650
4002												280	520	500	900	1500	400	1200	547	1910	2560
4003		315	520	500	900	1500	400	1200	547	1910	2640										
4005		400	520	500	900	1500	400	1200	547	1910	2880										
4501		450	600	480	1000	1760	450	1350	567	2160	3550										
4502		500	600	480	1000	1760	450	1350	567	2160	3670										
4503		560	600	480	1000	1760	450	1350	567	2160	3930										
4504		630	600	480	1000	1760	450	1350	567	2160	3960										
5001		710	680	560	1120	1940	500	1520	727	2430	4660										
5002		800	680	560	1120	1940	500	1520	727	2430	4830										
5003		900	680	560	1120	1940	500	1520	727	2430	4930										
5004		1000	680	560	1120	1940	500	1520	727	2430	5100										
5601		1120	750	800	1250	2000	560	1800	752	2490	5900										
5602		1250	750	800	1250	2000	560	1800	752	2490	6200										
5603		1400	750	800	1250	2000	560	1800	752	2490	6500										
6301		1600	840	800	1400	2400	630	2000	832	2930	8300										
6302		1800	840	800	1400	2400	630	2000	832	2930	8700										
6303	2000	840	800	1400	2400	630	2000	832	2930	9200											
7101	2240	1200	1200	1600	2400	710	2330	882	3201	10800											
7102	2500	1200	1200	1600	2400	710	2336	882	3208	11300											
7103	3150	1200	1200	1600	2400	710	2340	882	3210	11800											

DOUBLE SUCTION CENTRIFUGAL PUMP

FS SERIES / 单级双吸离心泵
FS系列

Pump type 泵型号	Flange size 法兰尺寸				Pump size 泵尺寸																Pump weight (kg) 泵质量
	DN1	DN2	S1	S2	B1	B2	e	f	h1	h2	h3	h4	L1	L2	L3	b1	b2	b3	b4		
FS600-560	700	600	54	48	1100	900	835	1030	1100	750	610	610	800	900	1200	400	700	400	500	4846	
FS600-600	700	600	54	48	1200	900	847	1098	1200	770	675	675	725	725	1070	670	670	525	525	4900	
FS600-630	700	600	54	48	1000	1000	790	1010	1050	650	545	545	900	900	1230	400	730	500	500	4442	
FS600-705	700	600	54	48	1150	1000	847	1098	1100	715	575	575	725	725	1090	670	670	525	525	4700	
FS600-710	700	600	54	48	1000	1100	880	1130	1050	650	545	545	900	900	1370	570	870	500	500	4573	
FS600-860	700	600	54	48	1100	1200	950	1225	1100	760	580	580	1000	900	1350	570	850	600	500	7050	
FS600-885	700	600	54	48	1300	1100	926	1280	1300	790	750	750	850	850	1070	670	670	650	650	5600	
FS600-1075	700	600	54	48	1250	1200	926	1280	1300	850	750	750	850	850	1150	750	750	650	650	5800	
Motor pole 电机极数	Pump type 泵型号				Motor type 电机型号	Motor power (Kw) 电机功率	L4	L5	b5	b6	h5	h6	c	q	Motor weight (kg) 电机重量						
	6	FS600-710	FS600-630	FS600-600	FS600-560	355L3	250	480	430	740	830	355	1035	426	1570	1650					
4002						280	520	500	900	1500	400	1200	547	1910	2560						
4003						355	520	500	900	1500	400	1200	547	1910	2640						
4501						450	600	480	1000	1760	450	1350	567	2160	3550						
4502						500	600	480	1000	1760	450	1350	567	2160	3670						
4503			560	600	480	1000	1760	450	1350	567	2160	3930									
4504			630	600	480	1000	1760	450	1350	567	2160	3960									
5001			710	680	560	1120	1940	500	1520	727	2430	4660									
5002			800	680	560	1120	1940	500	1520	727	2430	4830									
5003			900	680	560	1120	1940	500	1520	727	2430	4930									
5601		1120	750	800	1250	2000	560	1800	752	2490	5900										
5602		1250	750	800	1250	2000	560	1800	752	2490	6200										
5603		1400	750	800	1250	2000	560	1800	752	2490	6500										
6301		1600	840	800	1400	2400	630	2000	832	2930	8300										
6302		1800	840	800	1400	2400	630	2000	832	2930	8700										
6303		2000	840	800	1400	2400	630	2000	832	2930	9200										
7101		2240	1200	1200	1600	2400	710	2331	882	3201	10800										
7102		2500	1200	1200	1600	2400	710	2337	882	3207	11300										
7103		3150	1200	1200	1600	2400	710	2341	882	3211	11800										
8002		4000	1340	1400	1860	2600	800	2550	882	3420	16000										

FS

DIMENSION

DOUBLE SUCTION CENTRIFUGAL PUMP

FS SERIES / 单级双吸离心泵
FS系列

Pumptype 泵型号	Flange size 法兰尺寸				Pump size 泵尺寸																Pump weight (kg) 泵质量
	DN1	DN2	S1	S2	B1	B2	e	f	h1	h2	h3	h4	L1	L2	L3	b1	b2	b3	b4		
FS700-600	800	700	58	54	1300	800	1040	1250	1150	720	600	600	700	1000	1350	550	850	550	550	6065	
FS700-710	800	700	58	54	1200	1150	1080	1310	1170	750	620	620	1000	1000	1350	550	850	550	550	7994	
FS700-800	800	700	58	54	1250	1250	1110	1390	1200	850	650	650	1050	1050	1370	550	870	600	600	9113	
FS700-980	800	700	58	54	1300	1050	1011	1365	1500	930	850	850	850	850	1340	940	940	650	650	7700	
Motor pole 电机极数	Pump type 泵型号	Motor type 电机型号	Motor power (Kw) 电机功率	L4	L5	b5	b6	h5	h6	c	q	Motor weight (kg) 电机重量									
6	FS700-800	FS700-800	4503	560	600	480	1000	1760	450	1350	567	2160	3930								
			4504	630	600	480	1000	1760	450	1350	567	2160	3960								
			5001	710	680	560	1120	1940	500	1520	727	2430	4660								
			5003	900	680	560	1120	1940	500	1520	727	2430	4930								
			5004	1000	680	560	1120	1940	500	1520	727	2430	5100								
			5601	1120	750	800	1250	2000	560	1800	752	2490	5900								
			5602	1250	750	800	1250	2000	560	1800	752	2490	6200								
	FS700-980	FS700-980	5603	1400	750	800	1250	2000	560	1800	752	2490	6500								
			6302	1800	840	800	1400	2400	630	2000	832	2930	8700								
			6303	2000	840	800	1400	2400	630	2000	832	2930	9200								
			6302	1250	840	6302	1250	840	1000	1400	2200	630	2000								
			6303	1400	840	6303	1400	840	1000	1400	2200	630	2000								
			7101	1800	1200	7101	1800	1200	1200	1600	2400	710	2332								
			7102	2000	1200	7102	2000	1200	1200	1600	2400	710	2339								

DOUBLE SUCTION CENTRIFUGAL PUMP

FS SERIES / 单级双吸离心泵
FS系列

Pump type 泵型号	Flange size 法兰尺寸				pump size 泵尺寸																Pump weight(kg) 泵质量
	DN1	DN2	S1	S2	B1	B2	e	f	h1	h2	h3	h4	L1	L2	L3	b1	b2	b3	b4		
FS800-800	900	800	62	58	1400	950	1130	1360	1380	920	770	770	850	1000	1450	650	950	350	500	8542	
FS800-900	900	800	62	58	1400	1125	1130	1450	1360	900	770	770	1000	1050	1450	650	950	500	550	9936	
FS800-980	900	800	62	58	1400	1300	1220	1530	1370	850	760	760	1100	1100	1450	650	950	600	600	11714	
Motor pole 电机极数	Pump type 泵型号		Motor type 电机型号	Motor power (Kw) 电机功率	L4	L5	b5	b6	h5	h6	c	q	(kg)Motor weight 电机重量								
8	FS800-800	FS800-800	5003	630	680	850	1120	1650	500	1520	727	2200	4900								
			5004	710	680	850	1120	1650	500	1520	727	2200	5200								
			5601	800	750	800	1250	2000	560	1800	802	2540	5500								
			5602	900	750	800	1250	2000	560	1800	802	2540	5850								
			5603	1000	750	800	1250	2000	560	1800	802	2540	6250								
			6301	1120	840	1000	1400	2200	630	2000	832	2830	7500								
			6302	1250	840	1000	1400	2200	630	2000	832	2830	7800								
	FS800-900	FS800-900	6303	1400	840	1000	1400	2200	630	2000	832	2830	8200								
			6304	1600	840	1000	1400	2200	630	2000	832	2830	8600								
			7101	1800	1200	1200	1600	2400	710	2333	882	3203	11200								
			7103	2240	1200	1200	1600	2400	710	2342	882	3212	12200								

Pump type 泵型号	Flange size 法兰尺寸				pump size 泵尺寸																Pump weight (kg) 泵质量
	DN1	DN2	S1	S2	B1	B2	e	f	h1	h2	h3	h4	L1	L2	L3	b1	b2	b3	b4		
FS900-970	1000	900	50	46	1600	1300	1470	1780	1650	1265	975	975	1060	1260	1550	500	800	600	800	11125	
FS900-1030	1000	900	50	46	1600	1300	1470	1780	1650	1265	975	975	1060	1260	1550	500	800	600	800	11200	
FS900-1050	1000	900	50	46	1600	1300	1470	1780	1650	1265	975	975	1060	1260	1550	500	800	600	800	11851	
FS1000-1170	1200	1000	56	50	1800	1300	1575	1780	1820	1375	1040	1040	1060	1260	2150	1000	1400	550	750	16000	
Motor pole 电机极数	Pump type 泵型号	Motor type 电机型号	Motor power(Kw) 电机功率	L4	L5	b5	b6	h5	h6	c	q	(kg)Motor weight 电机重量									
10	FS900-970	6303	1400	840	1000	1400	2200	630	2000	832	2830	8200									
		7101	1600	1200	1200	1600	2400	710	2334	882	3204	11100									
	FS900-1030	7103	2000	1200	1200	1600	2400	710	2343	882	3213	12100									
	FS900-1050	8002	2500	1340	1400	1860	2600	800	2550	882	3420	16300									
12	FS900-970	6302	800	840	1000	1400	2200	630	2000	832	2830	7780									
	FS900-1030	7101	1120	1200	1200	1600	2400	710	2335	882	3205	11000									
	FS900-1050	7103	1400	1200	1200	1600	2400	710	2344	882	3214	12000									
16	FS1000-1170	8001	1600	1340	1400	1860	2600	800	2550	882	3420	15000									
		8002	1800	1340	1400	1860	2600	800	2550	882	3420	15700									
16	FS1000-1170	7103	800	1200	1200	1600	2400	710	2345	882	3215	11400									
		7104	900	1200	1200	1600	2400	710	2346	882	3216	11900									

FS

DIMENSION



